

LUCE ° TU

EVERY SPACE HAS ITS OWN LIGHT



LUCE TU COLLECTIBLE
COLLECTIONS



LUCE TU COLLECTIBLE

LIGHT AS SCULPTURE

BY ISACCO BRIOSCHI

“L’essere umano sta riscoprendo l’esigenza fondamentale di dare un senso intimo all’ambiente che lo circonda, creando una relazione tra ciò che percepisce e il proprio vissuto.

Il legame indissolubile tra spazio, luce e materia ci ha portato alla realizzazione di installazioni luminose fortemente materiche e tattili.

In questo contesto, il binomio tra arte e processo produttivo diventa l’essenza della scena illuminante: la luce emerge dalla materia, si fa spazio e costruisce nuove percezioni, rendendo lo spettatore parte attiva dell’esperienza.

Il design diventa così uno strumento espressivo, governato dalla luce, che trova la sua dualità tra materia e luogo.”

Le installazioni firmate dall’arch. Isacco Brioschi vivono al confine tra arte e design. La cura del dettaglio, la lavorazione artigianale e l’uso di materiali nobili traducono l’idea progettuale in oggetti unici, capaci di emozionare e dare profondità allo spazio.

Ogni creazione nasce dal dialogo con il sapere artigianale milanese e porta con sé l’identità autentica di chi l’ha realizzata.

“Human beings are rediscovering the fundamental need to give an intimate meaning to the environment around them, creating a connection between external perceptions and personal experience.

The inseparable relationship between space, light and matter has led us to create lighting installations that are deeply material and tactile.

In this context, the dialogue between art and production becomes the essence of the lighting scene: light emerges from matter, inhabits it and creates new perceptions, making the observer part of the experience.

Design becomes an expressive tool, shaped and guided by light, finding its balance between material and space.”

The installations designed by architect Isacco Brioschi exist at the intersection of art and design.

Attention to detail, artisanal craftsmanship and the use of noble materials transform the initial concept into unique pieces that evoke emotion and enrich the spatial experience.

Each creation is rooted in Milanese craftsmanship and carries the authentic identity of the hands that shaped it.

KOMOREBI/ BETULLA



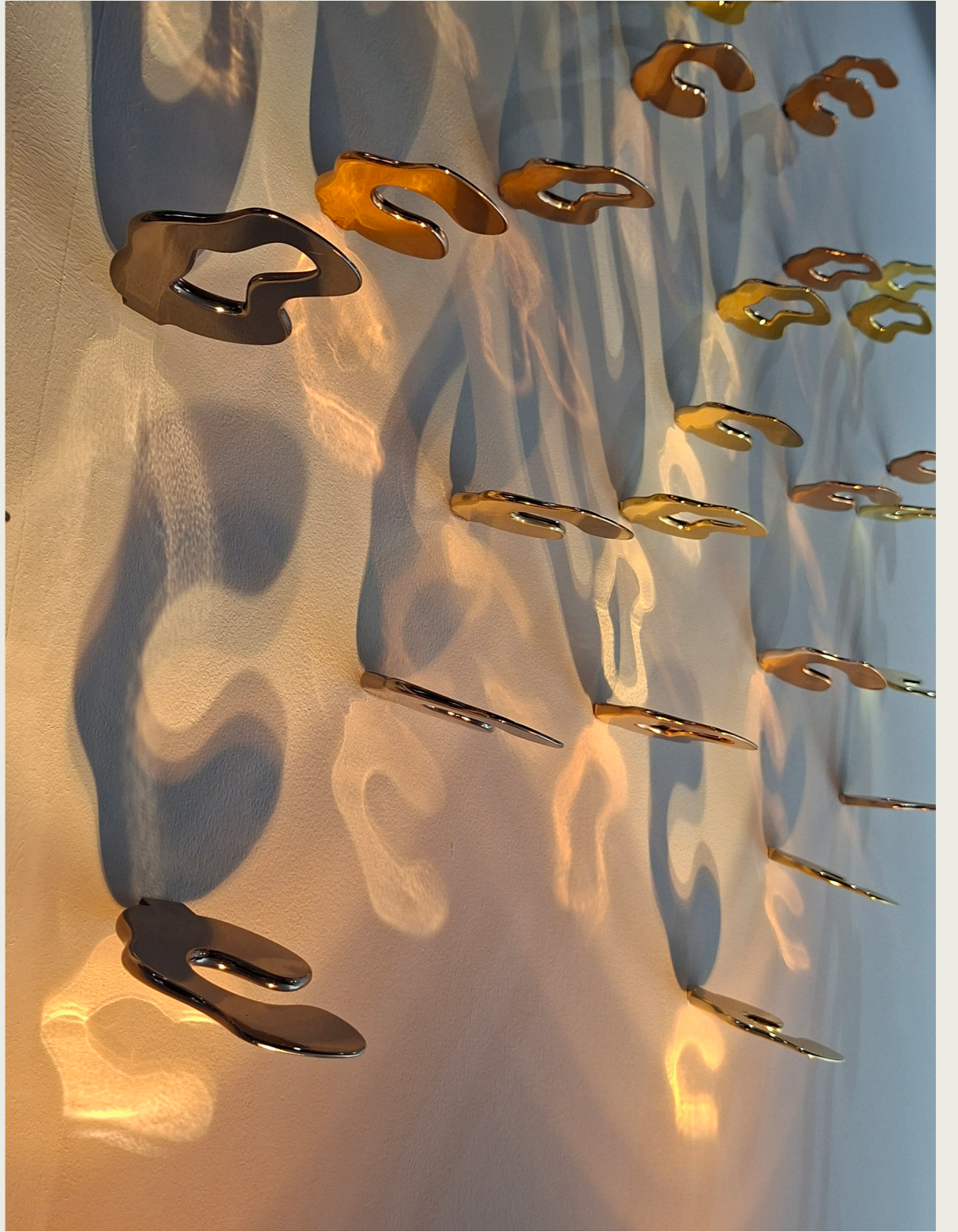

BETULLA

Cod: KMR.B
Light Source: Cob LED
Colour Temperature: 2700K



KOMOREBI/ FICO





FICO

Cod: KMR.F
Light Source: Cob LED
Colour Temperature: 2700 K



Illuminazione dal basso / lighting from below

KOMOREBI SINGOLA (12)

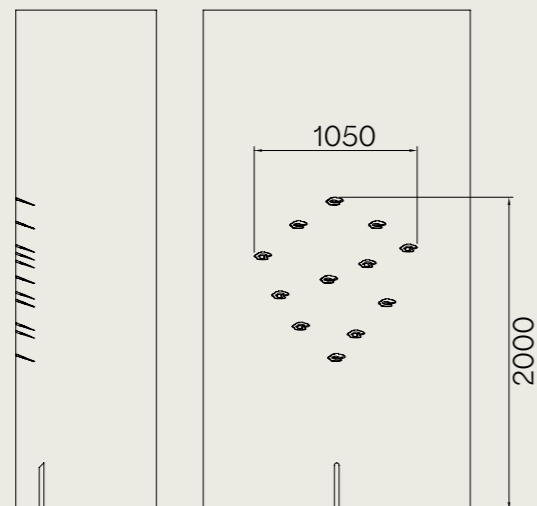

KOMOREBI SINGOLA (18)

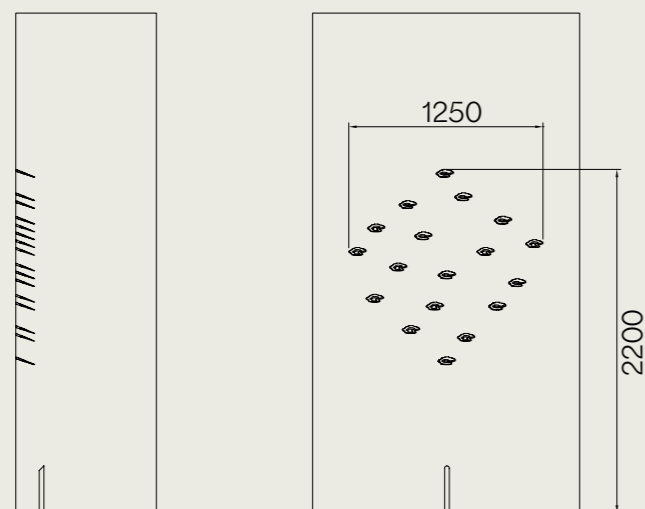

KOMOREBI DOPPIA (24)

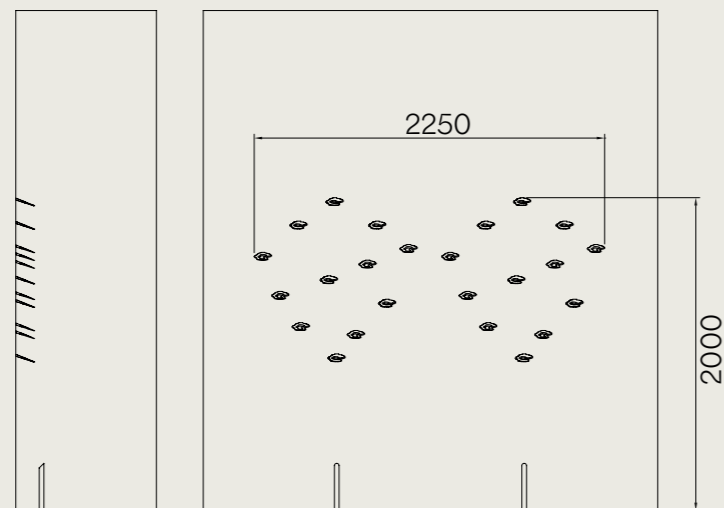

Illuminazione dall'alto / lighting from above

Misure in mm
Sizes in mm

KOMOREBI SINGOLA (15)

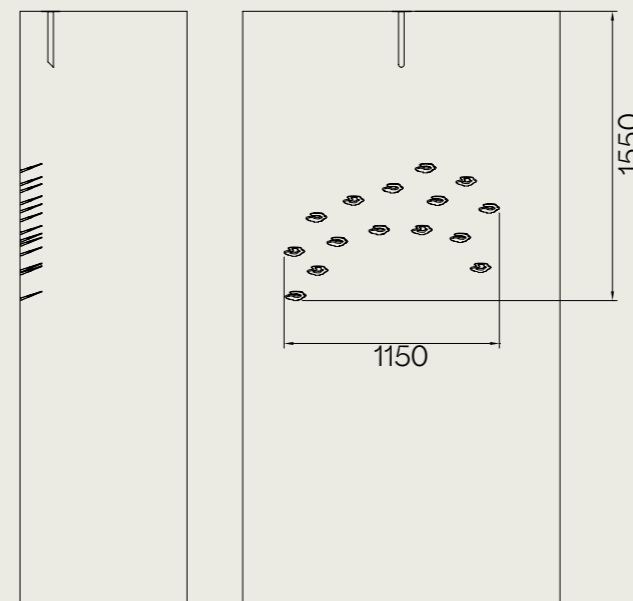

KOMOREBI DOPPIA (30)

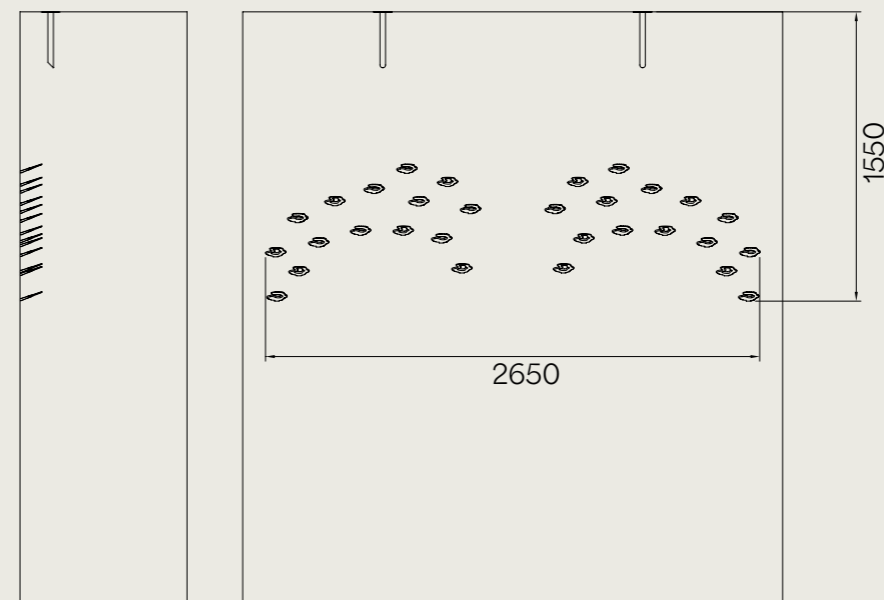

Tutte le quote e i disegni tecnici riportati nel presente catalogo sono da considerarsi indicativi. Trattandosi di prodotti artigianali, ogni lampada è realizzata singolarmente e potrebbe presentare lievi variazioni dimensionali e/o estetiche rispetto a quanto illustrato.

All dimensions and technical drawings shown in this catalogue are to be considered indicative. As these are handcrafted products, each lamp is individually made and may present slight variations in size and/or appearance compared to what is illustrated.

FIAMMETTA



FIAMMETTA

Cod: FMT
Light Source: Cob LED
Colour Temperature: 2700K

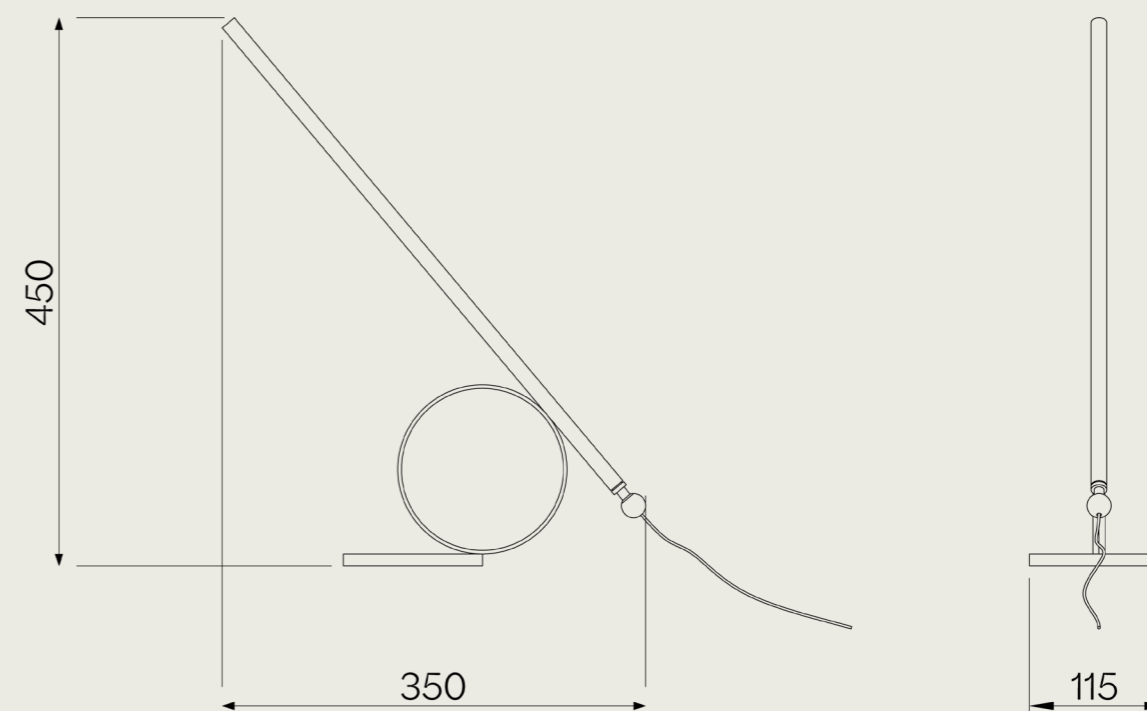

Tutte le quote e i disegni tecnici riportati nel presente catalogo sono da considerarsi indicativi. Trattandosi di prodotti artigianali, ogni lampada è realizzata singolarmente e potrebbe presentare lievi variazioni dimensionali e/o estetiche rispetto a quanto illustrato.

All dimensions and technical drawings shown in this catalogue are to be considered indicative. As these are handcrafted products, each lamp is individually made and may present slight variations in size and/or appearance compared to what is illustrated.

SCIGHERA/VÜN



Misure in mm
Sizes in mm

VÜN

Cod: SCL02
Light Source: Cob LED
Colour Temperature: 2700K

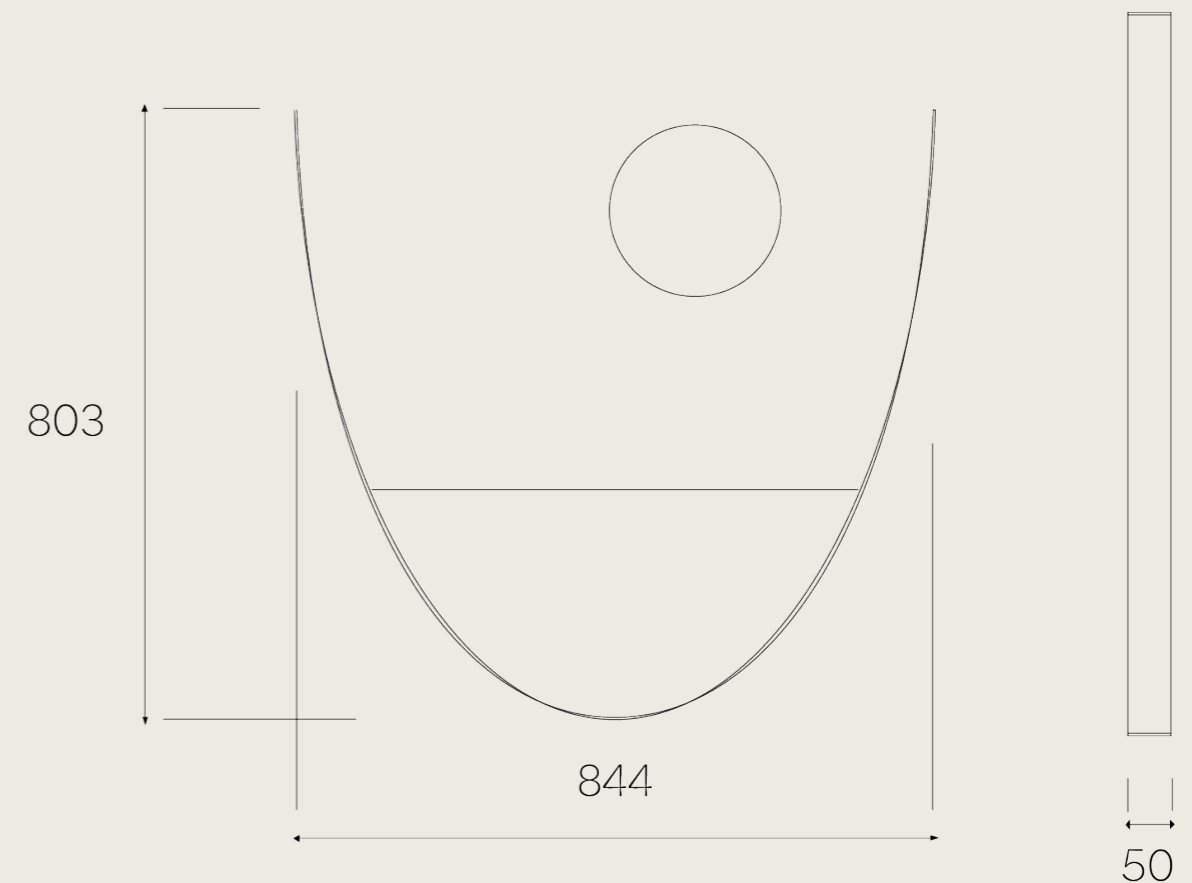

The new collections of light installations by Arch. Isacco Brioschi live on the borderline between art and design. Only 100 units will be produced, numbered and authenticated, each one handmade with processes that make each one unique and inimitable. 'The indissoluble link between space and artificial light, the concreteness sought in materiality, for this new collection, makes these light installations tactile, where the combination of art and production process becomes the essence of the illuminating stage. Light appears, making space in the material, communicating new scenarios and emotions, and becoming the protagonist through the morphology of light and its perspective thanks to kinetic and unexpected games that are transmitted outside and inside the sculpture itself. Design thus becomes unleashed by light itself, which acts as its sensorial protagonist, becoming a compositional and expressive tool in all respects.'

SCIGHERA/TRI



TRI

Cod: SCL03
Light Source: Strip LED
Colour Temperature: 2700 K

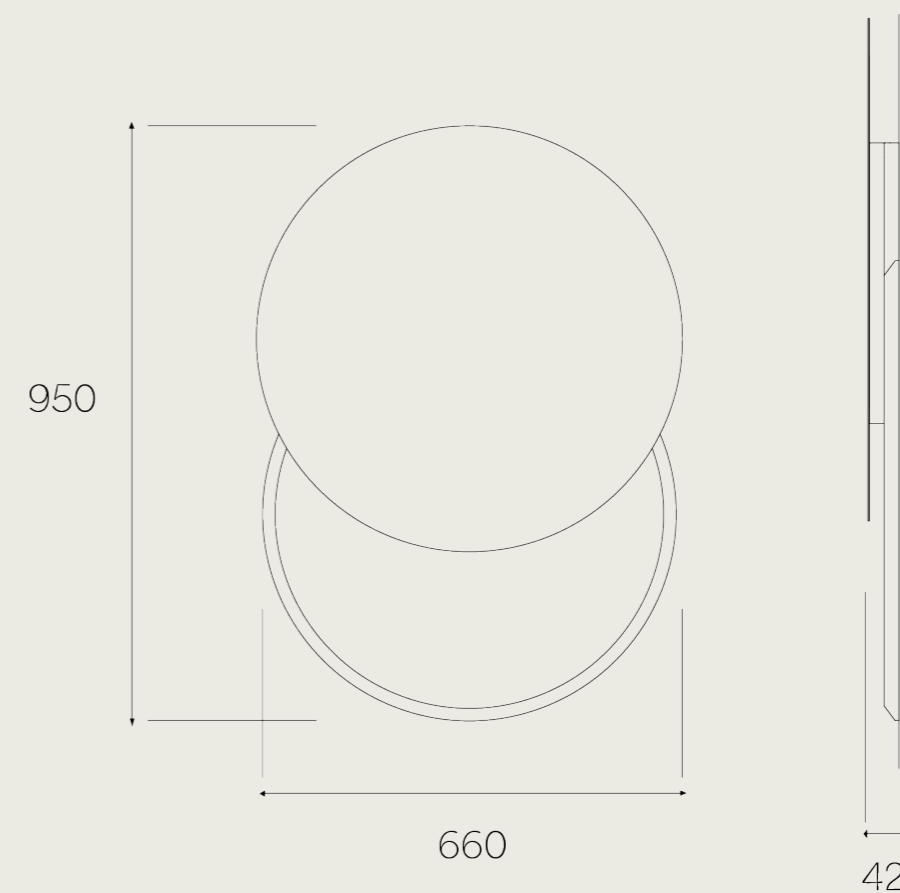

The new collections of light installations by Arch. Isacco Brioschi live on the borderline between art and design. Only 100 units will be produced, numbered and authenticated, each one handmade with processes that make each one unique and inimitable. 'The indissoluble link between space and artificial light, the concreteness sought in materiality, for this new collection, makes these light installations tactile, where the combination of art and production process becomes the essence of the illuminating stage. Light appears, making space in the material, communicating new scenarios and emotions, and becoming the protagonist through the morphology of light and its perspective thanks to kinetic and unexpected games that are transmitted outside and inside the sculpture itself. Design thus becomes unleashed by light itself, which acts as its sensorial protagonist, becoming a compositional and expressive tool in all respects.'

SCIGHERA/QUATER



Misure in mm
Sizes in mm

QUATER

Cod: SCL04
Light Source: Strip LED
Colour Temperature: 2700 K

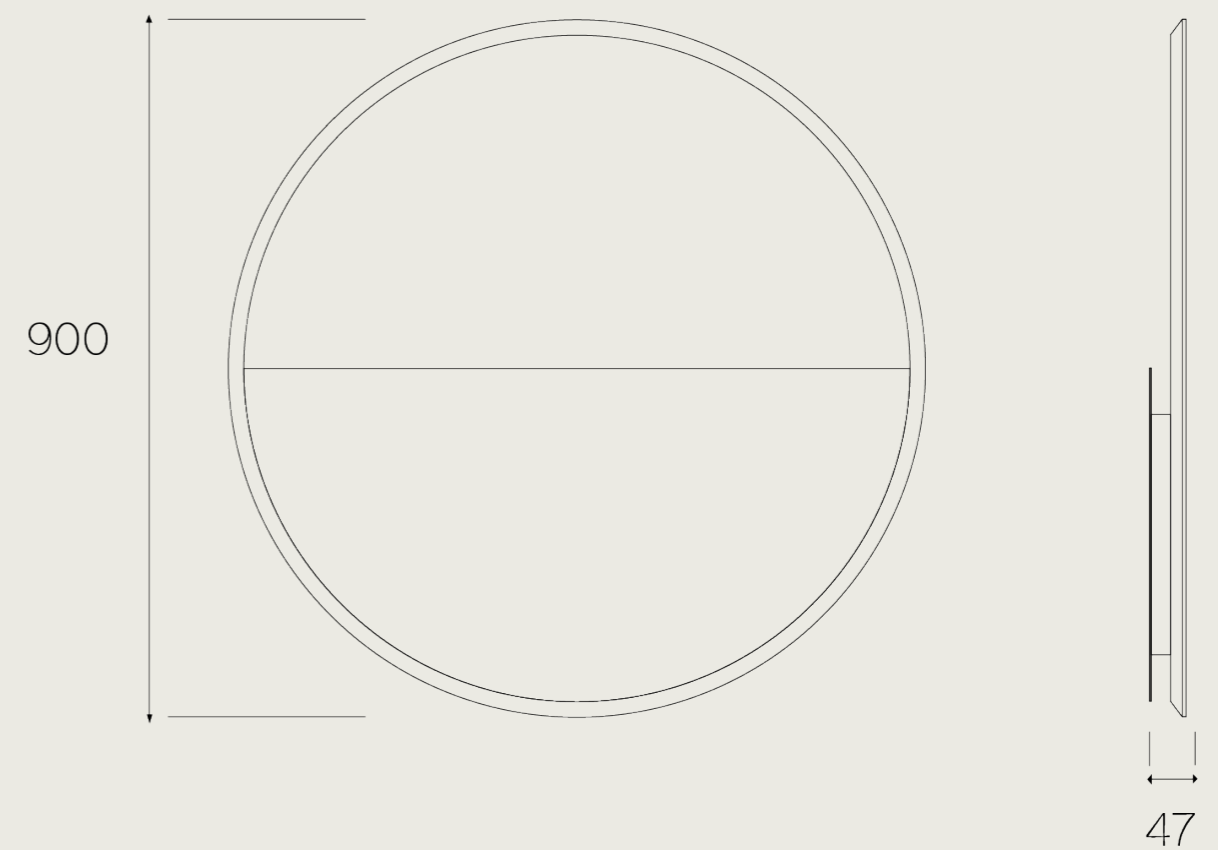

The new collections of light installations by Arch. Isacco Brioschi live on the borderline between art and design. Only 100 units will be produced, numbered and authenticated, each one handmade with processes that make each one unique and inimitable. 'The indissoluble link between space and artificial light, the concreteness sought in materiality, for this new collection, makes these light installations tactile, where the combination of art and production process becomes the essence of the illuminating stage. Light appears, making space in the material, communicating new scenarios and emotions, and becoming the protagonist through the morphology of light and its perspective thanks to kinetic and unexpected games that are transmitted outside and inside the sculpture itself. Design thus becomes unleashed by light itself, which acts as its sensorial protagonist, becoming a compositional and expressive tool in all respects.'

LAGHEE/VELA



VELA

Cod: VELA
Light Source: Cob LED
Colour Temperature: 2700K

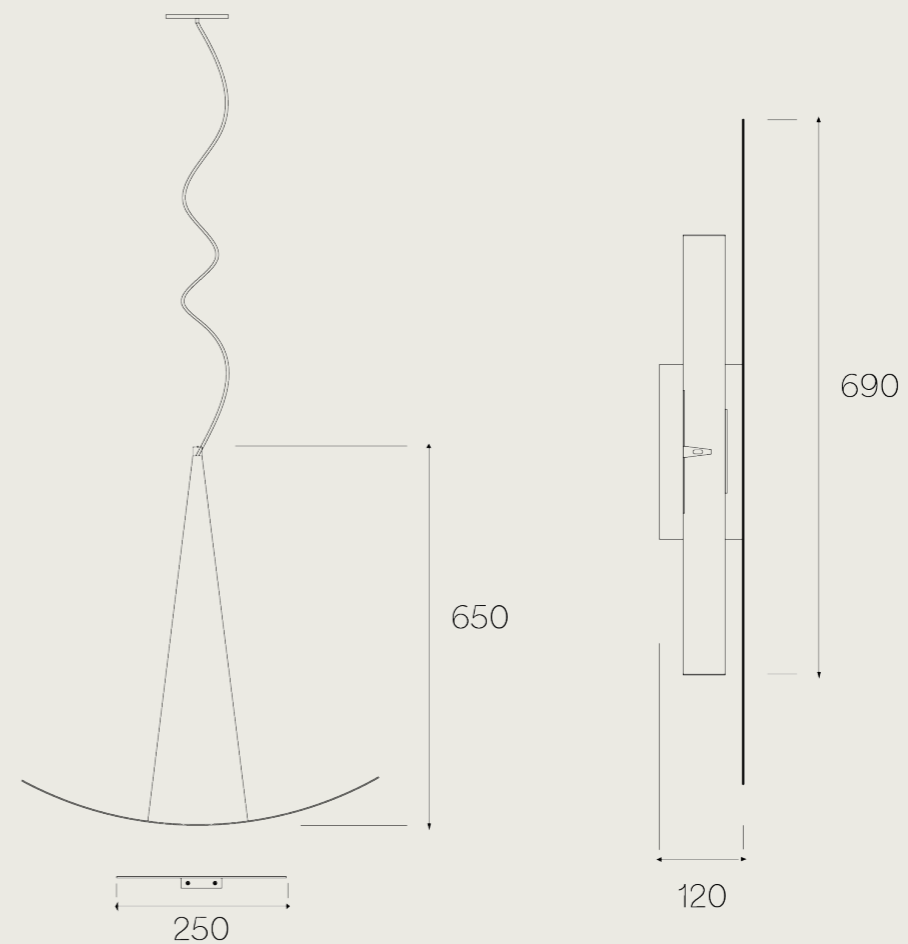

METAL FINISHING/FINITURE

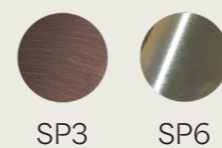

SP3

SP6

Tutte le quote e i disegni tecnici riportati nel presente catalogo sono da considerarsi indicativi. Trattandosi di prodotti artigianali, ogni lampada è realizzata singolarmente e potrebbe presentare lievi variazioni dimensionali e/o estetiche rispetto a quanto illustrato.

All dimensions and technical drawings shown in this catalogue are to be considered indicative. As these are handcrafted products, each lamp is individually made and may present slight variations in size and/or appearance compared to what is illustrated.

LAGHEE/LUNA



Misure in mm
Sizes in mm

LUNA

Cod: CRT02
Light Source: Cob LED
Colour Temperature: 2700K

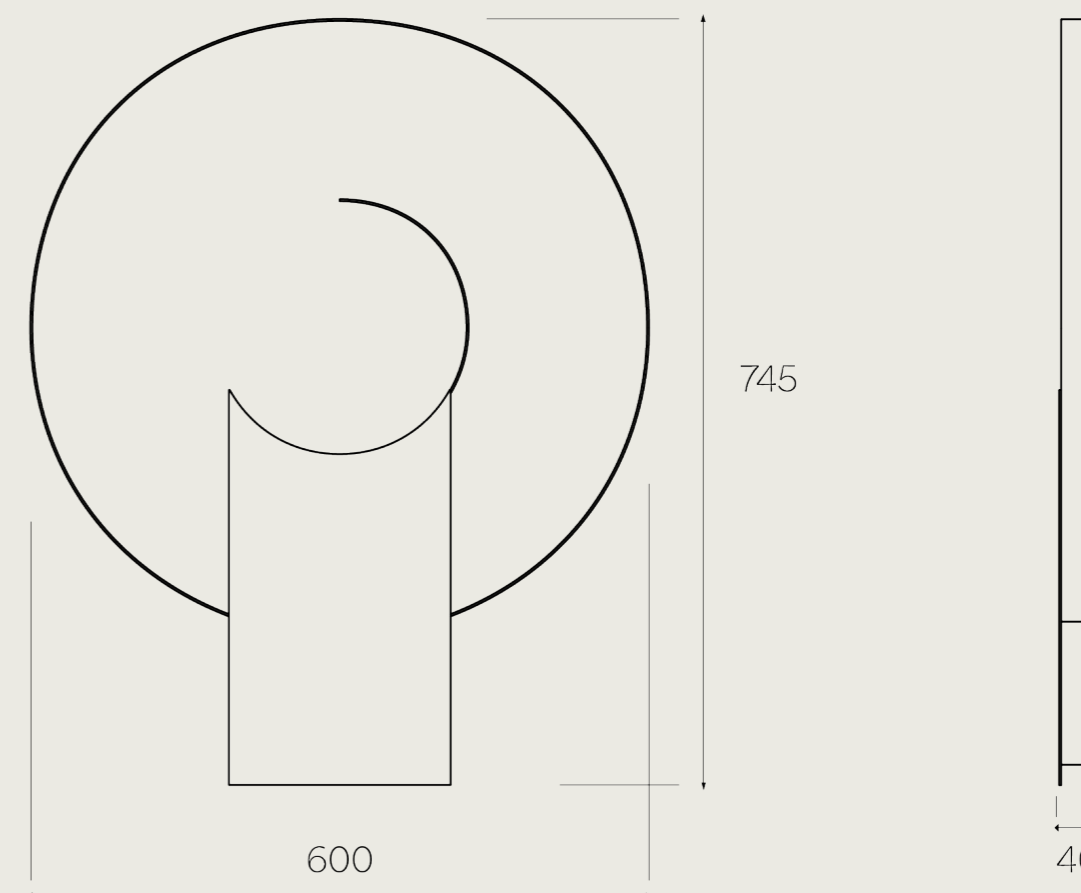

METAL FINISHING/FINITURE

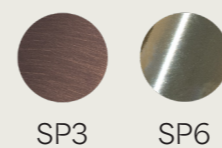

SP3

SP6

Tutte le quote e i disegni tecnici riportati nel presente catalogo sono da considerarsi indicativi. Trattandosi di prodotti artigianali, ogni lampada è realizzata singolarmente e potrebbe presentare lievi variazioni dimensionali e/o estetiche rispetto a quanto illustrato.

All dimensions and technical drawings shown in this catalogue are to be considered indicative. As these are handcrafted products, each lamp is individually made and may present slight variations in size and/or appearance compared to what is illustrated.

SCUR & CIAR / CIAR 01



/ CIAR 02



SC01/SC02

Cod: SC01 / SC02
Light Source: Strip LED
Colour Temperature: 2700K

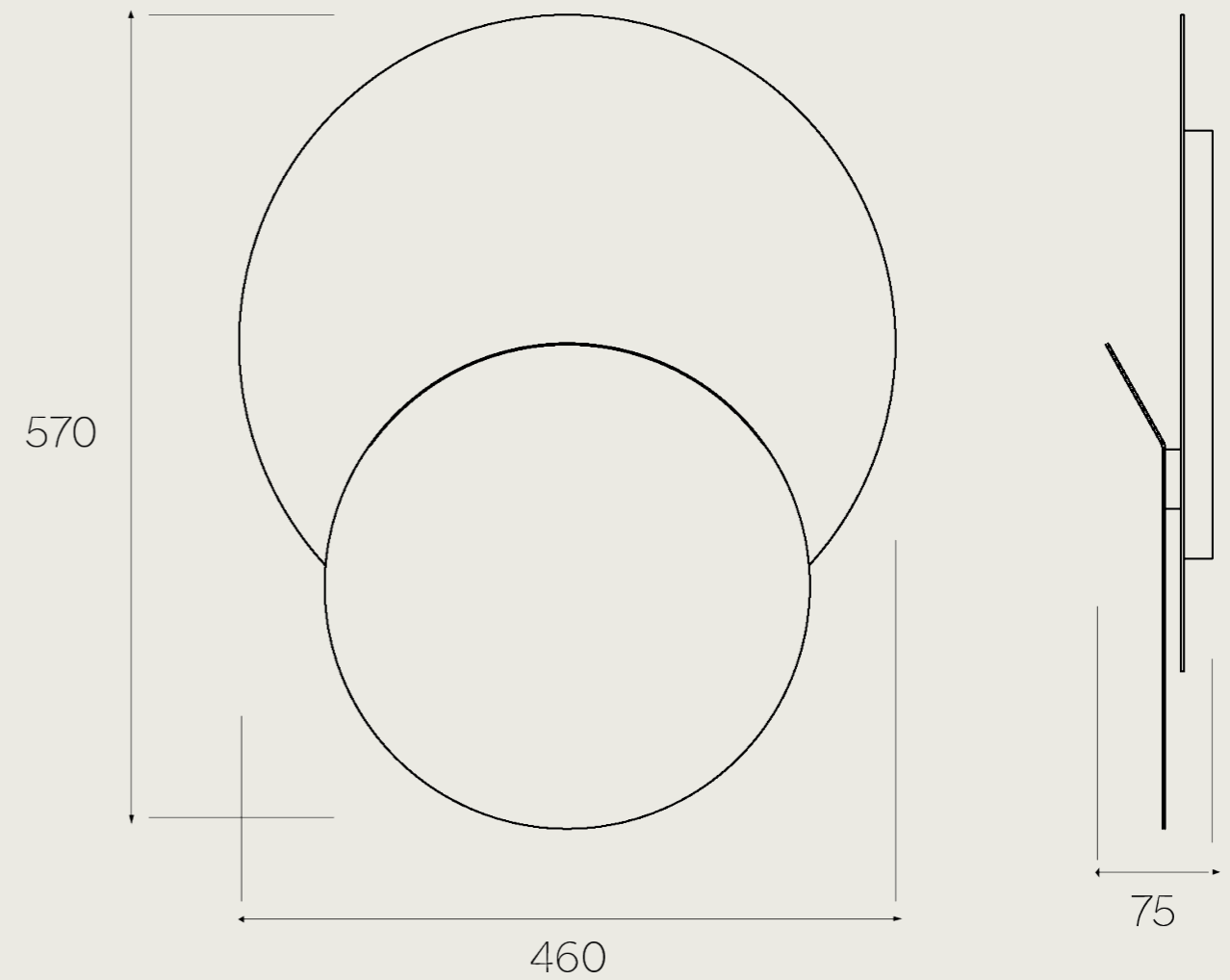

METAL FINISHING/FINITURE

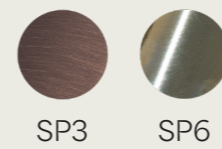

Tutte le quote e i disegni tecnici riportati nel presente catalogo sono da considerarsi indicativi. Trattandosi di prodotti artigianali, ogni lampada è realizzata singolarmente e potrebbe presentare lievi variazioni dimensionali e/o estetiche rispetto a quanto illustrato.

All dimensions and technical drawings shown in this catalogue are to be considered indicative. As these are handcrafted products, each lamp is individually made and may present slight variations in size and/or appearance compared to what is illustrated.

LUCE ◦ TU

SHOWROOM
VIA LAMBRATE 3 - MILANO

DESIGN LAB
PIAZZA BERTARELLI 4 - MILANO

INFO@LUCETU.COM | WWW.LUCETU.COM