

LUCE ° TU

EVERY SPACE HAS ITS OWN LIGHT

EVERYONE DESERVES ITS OWN LIGHT

LUCE TU EXISTS TO FIND IT



LIGHT AS AN EXPRESSION OF SPACE

EVERY ENVIRONMENT HAS ITS OWN LUMINOUS IDENTITY.

LUCE TU nasce a Milano dall'idea di trasformare la tradizione artigianale locale in un nuovo modo di progettare la luce.

Non una semplice azienda, ma una sartoria della luce.

Non un luogo unico di produzione, ma una fabbrica diffusa fatta di botteghe artigiane e manifatture specializzate.

All'interno di questo network milanese, materiali nobili e lavorazioni d'eccellenza prendono forma grazie a mani esperte che custodiscono il sapere dell'alta manifattura italiana.

Ogni progetto nasce dall'ascolto dello spazio e della persona che lo abita.

Perché ogni ambiente ha una propria identità luminosa.

LUCE TU nasce per dare a ciascuno la sua luce.

LUCE TU was founded in Milan with the idea of transforming local craftsmanship into a new way of designing light.

Not simply a company, but a tailoring atelier for light.

Not a single production site, but a distributed workshop composed of specialised artisans and manufacturers.

Within this Milanese network, noble materials and refined techniques take shape through expert hands that preserve the heritage of Italian high craftsmanship.

Each project begins by listening to the space and the people who inhabit it.

Because every environment has its own luminous identity.

LUCE TU exists to give everyone their own light.

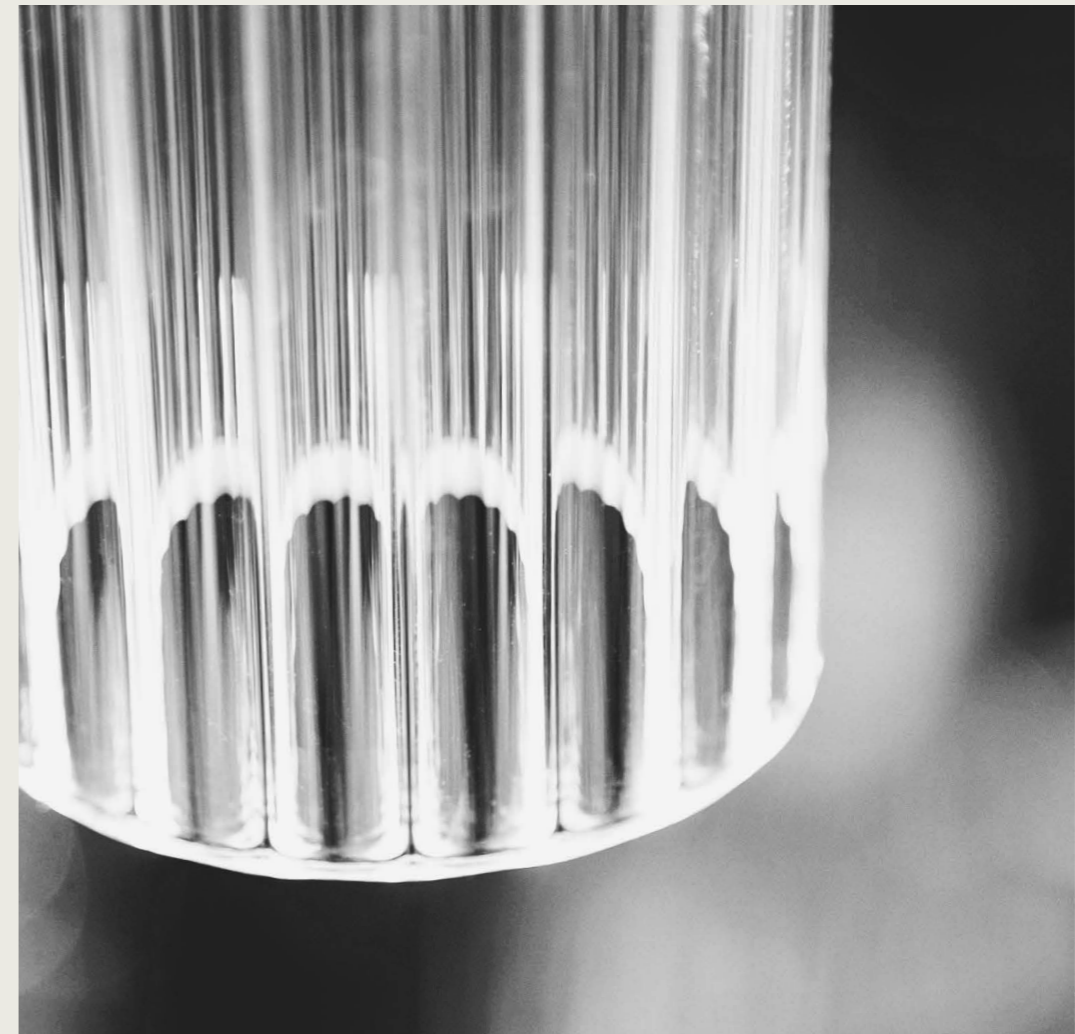



MILANO, CAPITAL OF DESIGN

WHERE DESIGN CULTURE MEETS CRAFTSMANSHIP.

Milano è il punto di partenza di LUCE TU.

Capitale italiana del design e della moda, la città custodisce una lunga tradizione estetica che ha contribuito a definire il linguaggio del progetto contemporaneo. Qui convivono cultura industriale, botteghe artigiane storiche e realtà manifatturiere altamente specializzate.

È all'interno di questo ecosistema creativo che nasce il network produttivo di LUCE TU: una rete di artigiani e aziende che lavorano vetro, metallo, tessuti e materiali preziosi con maestria tramandata da generazioni.

La stessa cultura della manifattura che rende riconoscibile nel mondo l'eccellenza dei grandi brand italiani.

Milan is LUCE TU's starting point.

As Italy's capital of design and fashion, the city holds a long aesthetic tradition that has helped shape the language of contemporary design.

Here, industrial culture coexists with historic workshops and highly specialised manufacturers.

Within this creative ecosystem, LUCE TU's production network takes shape: a constellation of artisans and companies working glass, metal, textiles and precious materials with expertise passed down through generations.

The same culture of craftsmanship that defines the excellence of the world's most renowned Italian brands.





HANDS SHAPING LIGHT

CRAFTSMANSHIP AS A LIVING CULTURE.



LUCE TU opera come una fabbrica diffusa.

Un network produttivo composto da botteghe artigiane e manifatture specializzate che custodiscono i segreti dell'alta lavorazione milanese.

Vetro soffiato, ottone lavorato, pietre naturali e metalli preziosi vengono trasformati attraverso tecniche tramandate nel tempo.

Ogni lampada è il risultato di una collaborazione tra progetto, materia e competenza artigianale.

LUCE TU operates as a distributed workshop.

A production network composed of artisanal ateliers and specialised manufacturers that preserve the secrets of Milanese craftsmanship.

Blown glass, crafted brass, natural stone and noble metals are shaped through techniques passed down over generations.

Each lamp results from the dialogue between design, material and artisanal expertise.



FROM SKETCH TO LIGHT

WHERE IDEAS TAKE SHAPE.

Ogni creazione LUCE TU nasce da uno schizzo.

Da questa prima intuizione prende avvio un processo progettuale che coinvolge il nostro network artigianale per individuare materiali e lavorazioni capaci di valorizzare l'idea iniziale.

Il prototipo viene sviluppato, ingegnerizzato e perfezionato fino a diventare una lampada pronta a entrare nello spazio.

Da qui il progetto può evolversi in un pezzo unico su misura oppure in una mini collezione pensata per il contract.

Every LUCE TU creation begins with a sketch.

From this first intuition, a design process unfolds involving our artisanal network to identify materials and techniques capable of enhancing the original idea.

The prototype is developed, engineered and refined until it becomes a lamp ready to inhabit a space.

From here the project may evolve into a unique bespoke piece or a small collection developed for contract environments.





TIMELESS SHAPES

DESIGN ROOTED IN CRAFTSMANSHIP.



Le collezioni LUCE TU interpretano il linguaggio del neo-classico contemporaneo. Forme essenziali, materiali nobili e lavorazioni artigianali si combinano per dare vita a lampade pensate per attraversare il tempo con eleganza. Oggetti luminosi che dialogano con l'architettura e contribuiscono a definire l'atmosfera dello spazio.

LUCE TU collections express a contemporary neo-classical language. Essential forms, noble materials and artisanal craftsmanship come together to create lamps designed to endure over time with elegance. Luminous objects that interact with architecture and help shape the atmosphere of space.





DOM



DOM

ARCHITECTURE TRANSFORMED INTO LIGHT

Ispirata al simbolo più iconico di Milano, la collezione Dom unisce rigore formale e ricchezza materica. Vetro borosilicato, ottone e sfere di pietra si combinano in una composizione elegante che richiama l'equilibrio tra architettura, tradizione e design contemporaneo.

Inspired by Milan's most iconic symbol, Dom combines formal rigour with refined materials. Borosilicate glass, brass and stone spheres create an elegant composition reflecting the balance between architecture, tradition and contemporary design.



DOM / SUSPENSION



DS01-DSM01



DOM / SUSPENSION



DS02-DSM02



DOM / CEILING



DC01-DCM01



DOM / FLOOR



DF01



DOM / TABLE



DT01 - DTM01





DOM/ TECHNICAL DRAWINGS SCHEDE TECNICHE

Tutte le quote e i disegni tecnici riportati nel presente catalogo sono da considerarsi indicativi.
Trattandosi di prodotti artigianali, ogni lampada è realizzata singolarmente e potrebbe presentare
lievi variazioni dimensionali e/o estetiche rispetto a quanto illustrato.

*All dimensions and technical drawings shown in this catalogue are to be considered
indicative. As these are handcrafted products, each lamp is individually made and may
present slight variations in size and/or appearance compared to what is illustrated.*

DS01/DSM01

Type:	Ceiling	
Light Source:	Cob LED	
CRI:	90	
Class:	IP20	
Colour Temperature:	3000K	
Driver:	On/Off	Dali Dimmable
Watt:	8W	11W
Lumens:	1274 Lm	1752 Lm

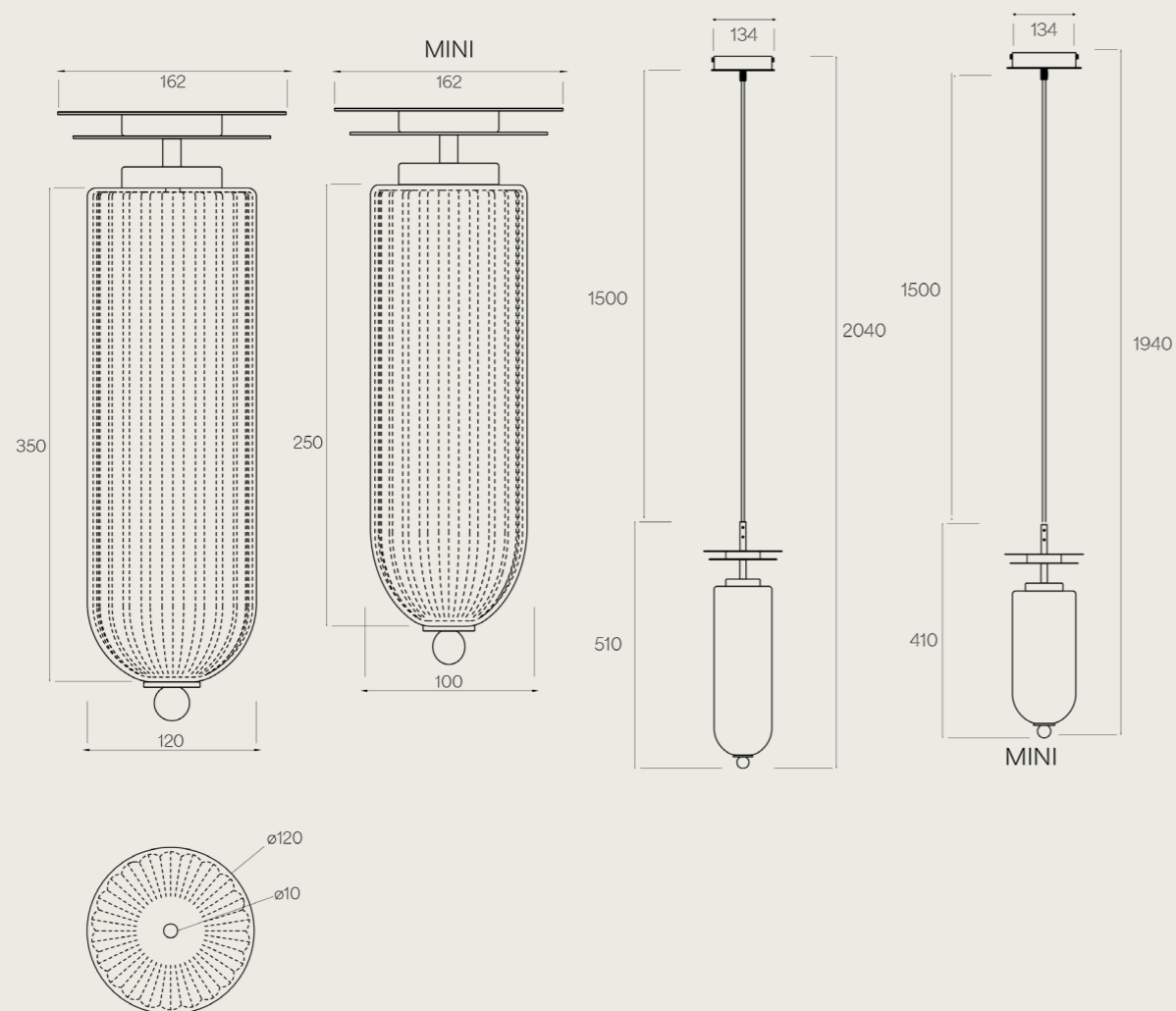

DS02-DSM02

Type:	Ceiling	
Light Source:	Cob LED	
CRI:	90	
Class:	IP20	
Colour Temperature:	3000K	
Driver:	On/Off	Dali Dimmable
Watt:	8W	11W
Lumens:	1274 Lm	1752 Lm

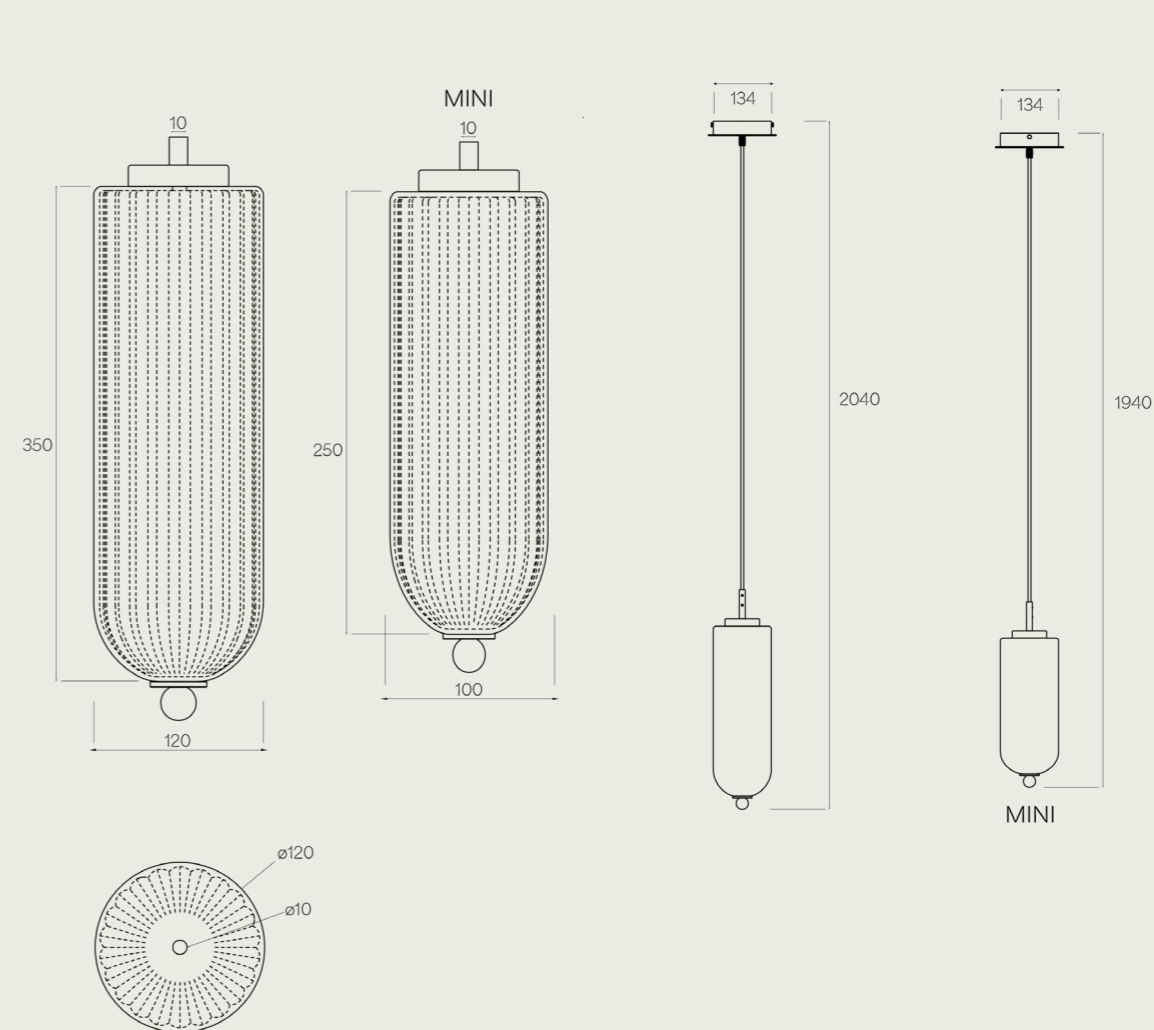

METAL FINISHING/FINITURE



SPHERES/SFERE



DC01/DCM01

Type:	Ceiling	
Light Source:	Cob LED	
CRI:	90	
Class:	IP20	
Colour Temperature:	3000K	
Driver:	On/Off	Dali Dimmable
Watt:	8W	11W
Lumens:	1274 Lm	1752 Lm

DF01

Type:	Floor	
Light Source:	Cob LED	
CRI:	90	
Class:	IP20	
Colour Temperature:	3000K	
Driver:	On/Off	Dali Dimmable
Watt:	8W	11W
Lumens:	1274 Lm	1752 Lm

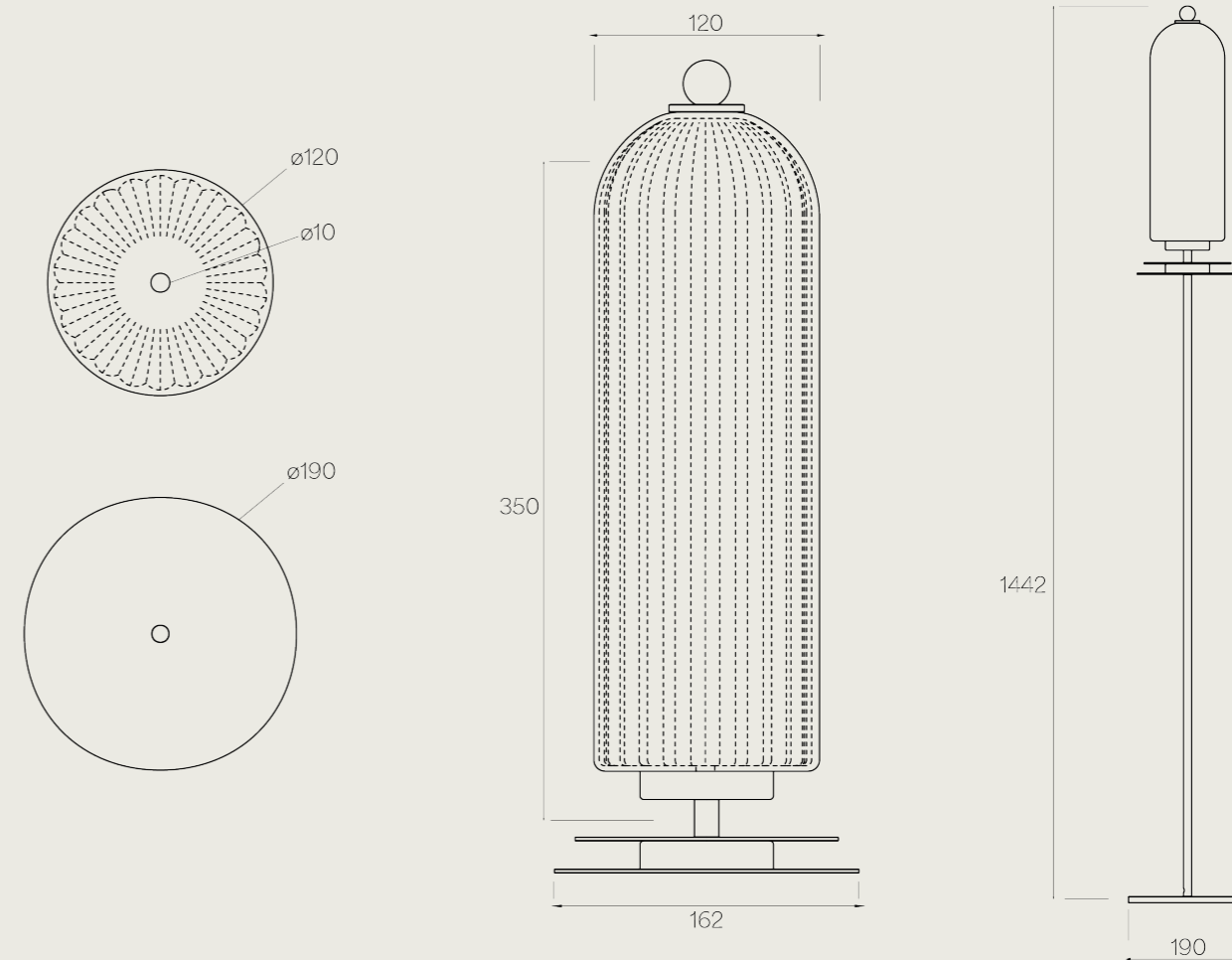
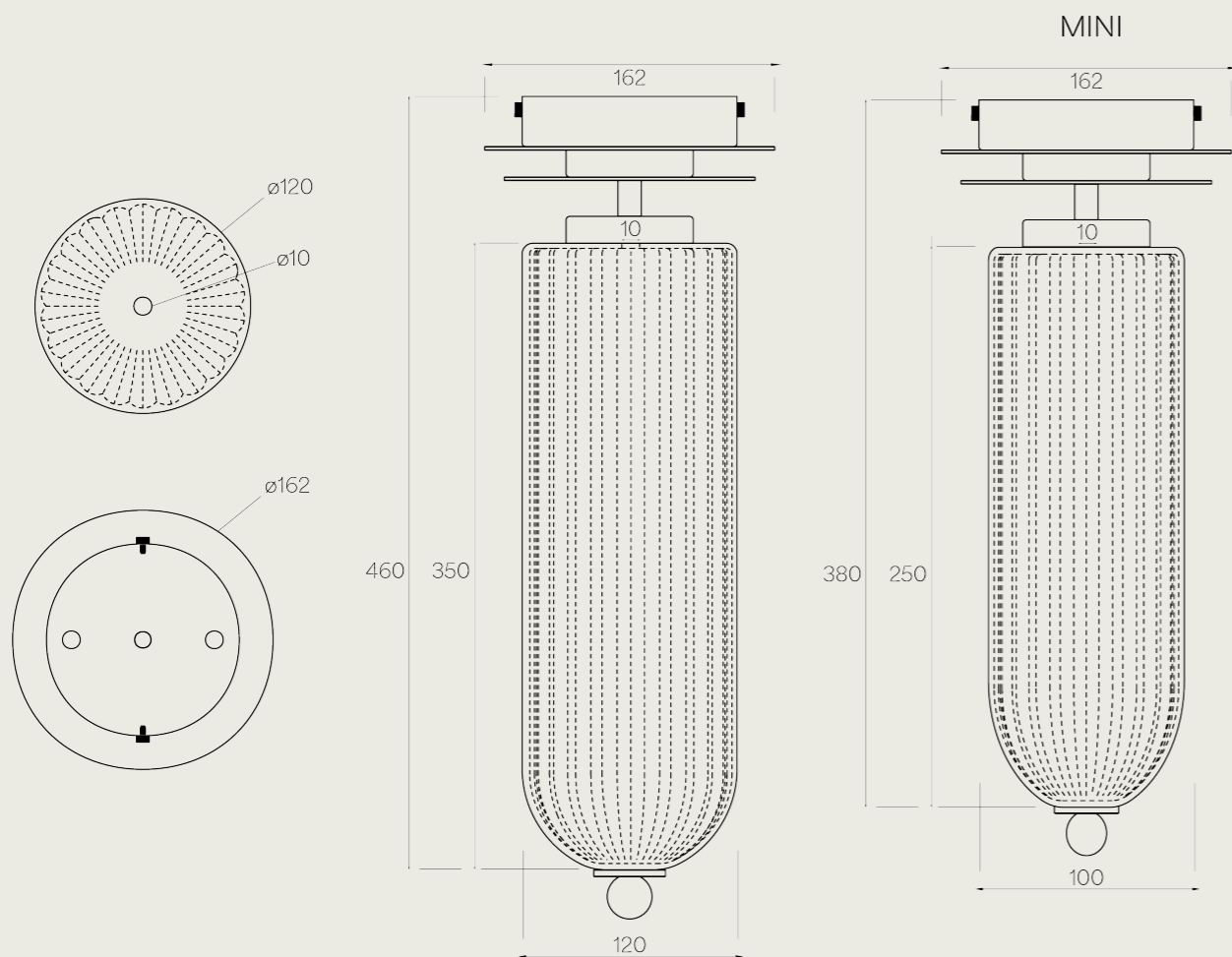

METAL FINISHING/FINITURE



SPHERES/SFERE

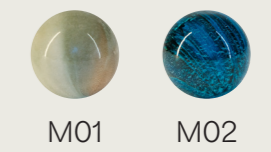

DT01/ DTM01

Type:	Table	
Light Source:	Cob LED	
CRI:	90	
Class:	IP20	
Colour Temperature:	3000K	
Driver:	On/Off	Dali Dimmable
Watt:	8W	11W
Lumens:	1274 Lm	1752 Lm

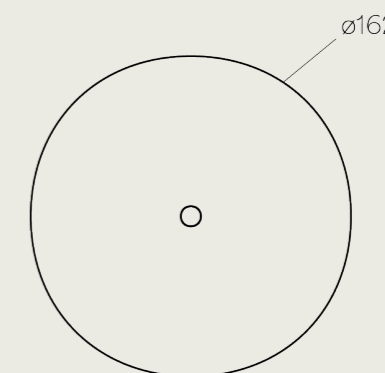
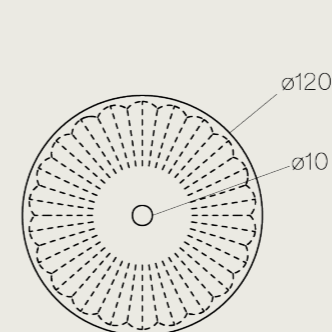
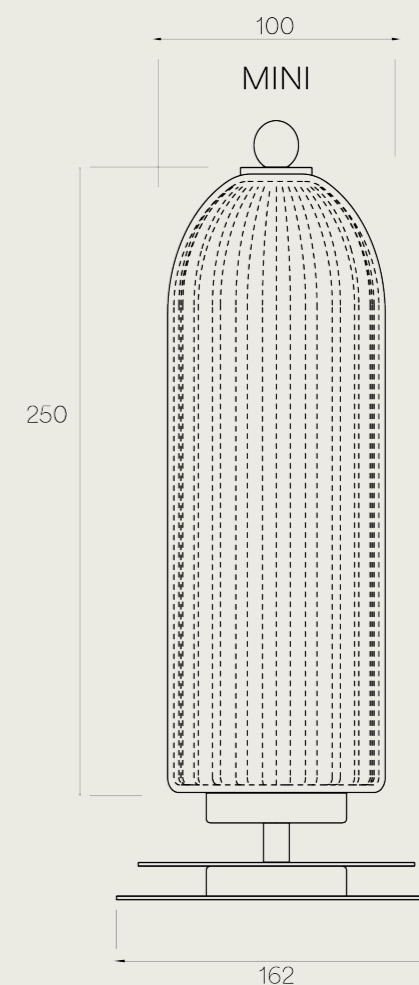
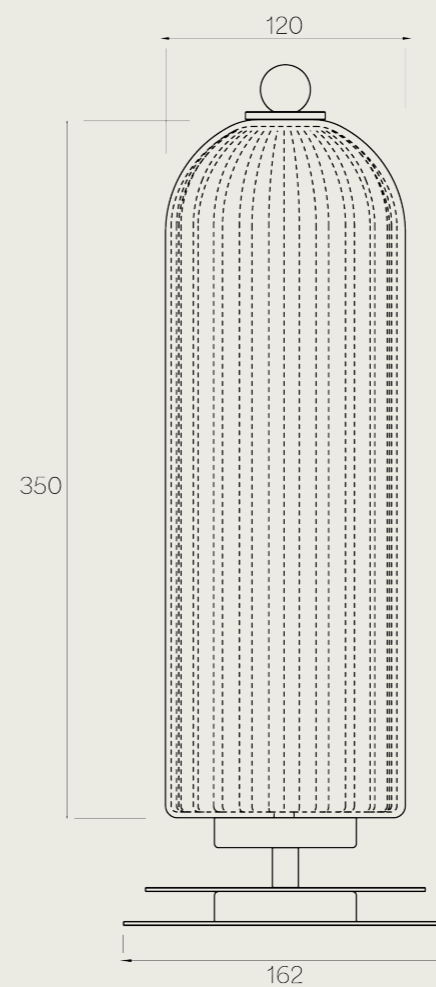

METAL FINISHING/FINITURE



SPHERES/SFERE



FINITURE/FINISHES

VETRI/GLASSES

STANDARD

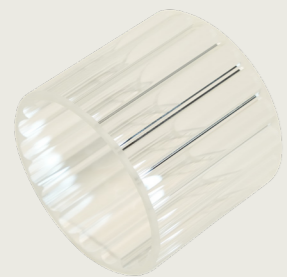

VC0

SFERE/SPHERES

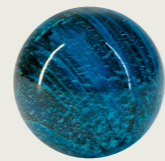

M01

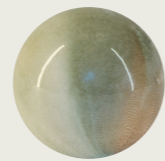

M02

GALVANICA/GALVANIC

STANDARD



B01
SATIN GUNMETAL



G02
SATIN CHAMPAGNE

SPECIAL



SP3
SATIN BRONZE



SP4
SATIN INOX



SP5
SATIN COPPER



SP6
SHINY GOLD





SBARLUSC

A SMALL GESTURE OF LIGHT

Nel dialetto milanese sbàrlusc indica il luccichio improvviso di un oggetto prezioso. La collezione interpreta questa suggestione creando una lampada capace di diffondere una luce morbida e avvolgente.

In Milanese dialect sbàrlusc describes the sudden sparkle of a precious object. The collection translates this idea into a lamp that emits a soft and enveloping glow, able to enhance the space with charm and refinement.



SBARLUSC / FLOOR



SB.SF01



SBARLUSC / TABLE



SB.ST01



SBARLUSC / WALL



SB.SW01



SBARLUSC / WALL



SB.SW02



SBARLUSC / WALL MINI



SB.SM01



SBARLUSC / WALL MINI



SB.SM02



SBARLUSC / DOUBLE SUSPENSION



SB.SS02-SS02B



SBARLUSC / SUSPENSION



SB.SS03/04



SBARLUSC / WALL

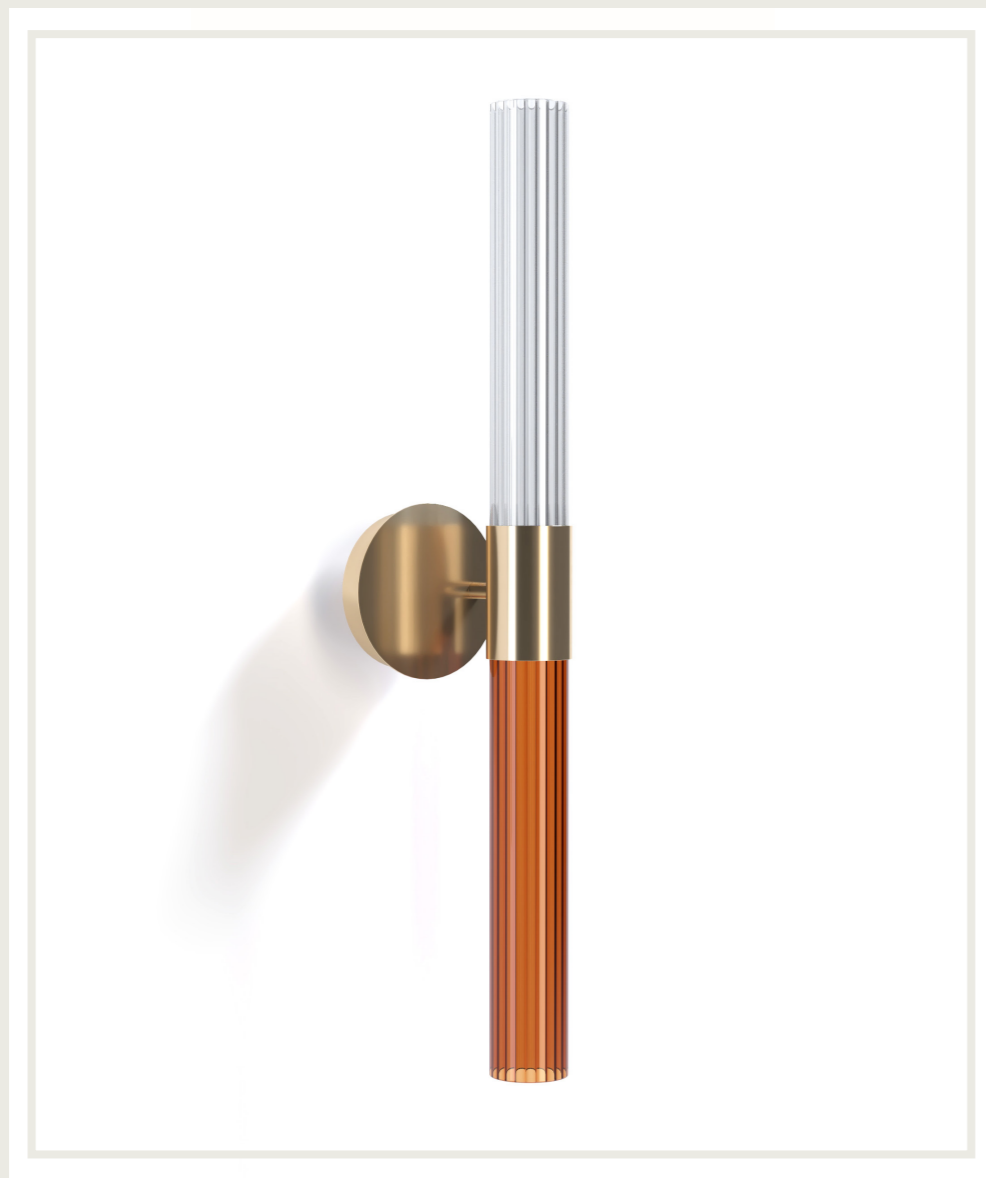

SB.SL01





SBARLUSC / TECHNICAL DRAWINGS SCHEDE TECNICHE

Tutte le quote e i disegni tecnici riportati nel presente catalogo sono da considerarsi indicativi.
Trattandosi di prodotti artigianali, ogni lampada è realizzata singolarmente e potrebbe presentare
lievi variazioni dimensionali e/o estetiche rispetto a quanto illustrato.

*All dimensions and technical drawings shown in this catalogue are to be considered
indicative. As these are handcrafted products, each lamp is individually made and may
present slight variations in size and/or appearance compared to what is illustrated.*

SB.SF01

Type: Floor
 Light Source: Cob LED
 CRI: 90
 Class: IP20
 Colour Temperature: 3000K
 Driver: On/Off - Dimmable
 Watt: 15W 100-240V
 Lumens: 900 Lm

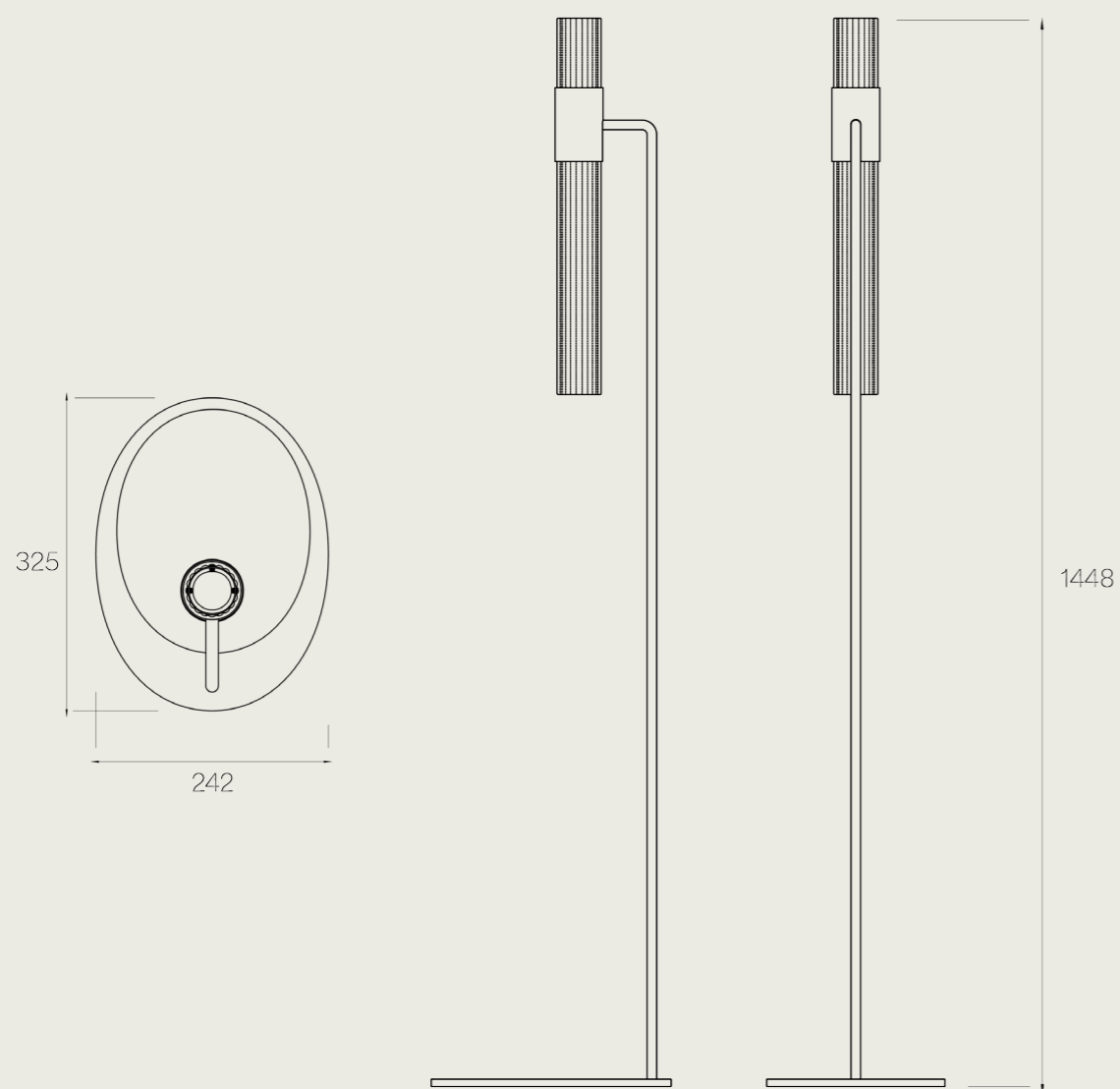

METAL FINISHING/FINITURE



SB.ST01

Type: Table
 Light Source: Cob LED
 CRI: 90
 Class: IP20
 Colour Temperature: 3000K
 Driver: On/Off - Dimmable
 Watt: 15W 100-240V
 Lumens: 450 Lm

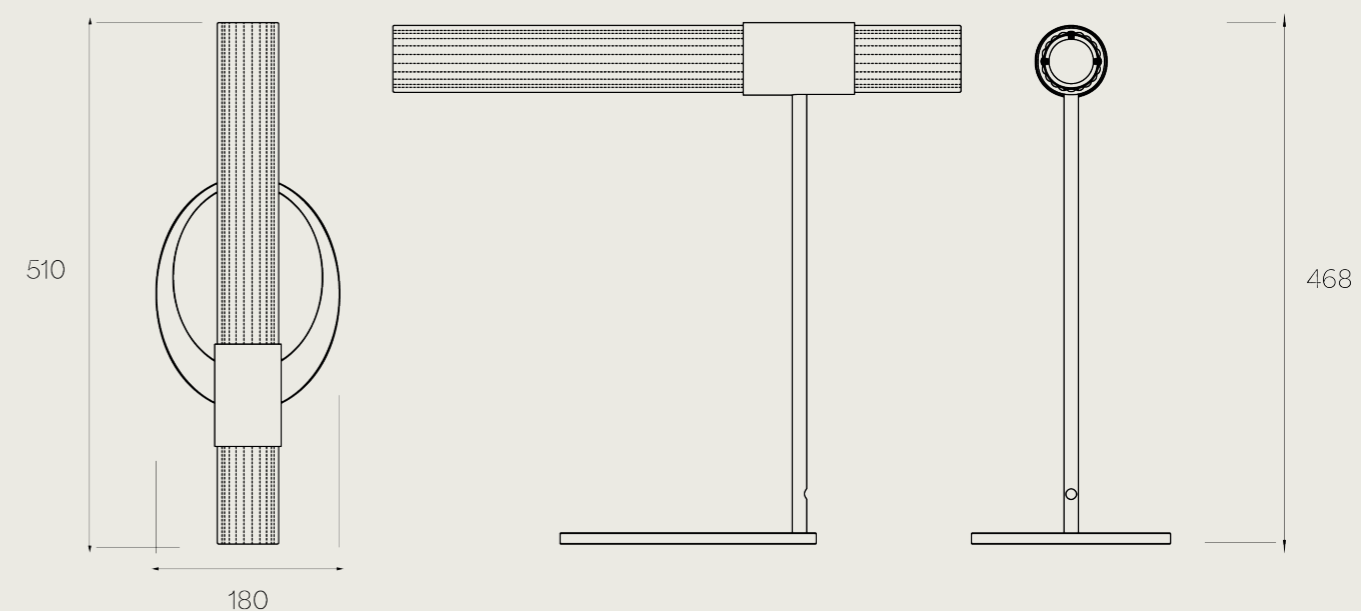

GLASSES/VETRI

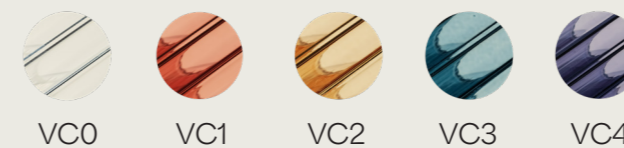

SB.SW01

Type: Wall
 Light Source: Cob LED
 CRI: 90
 Class: IP20
 Colour Temperature: 3000K
 Driver: On/Off - Dimmable on request
 Watt: 8W 100-240V
 Lumens: 900 Lm

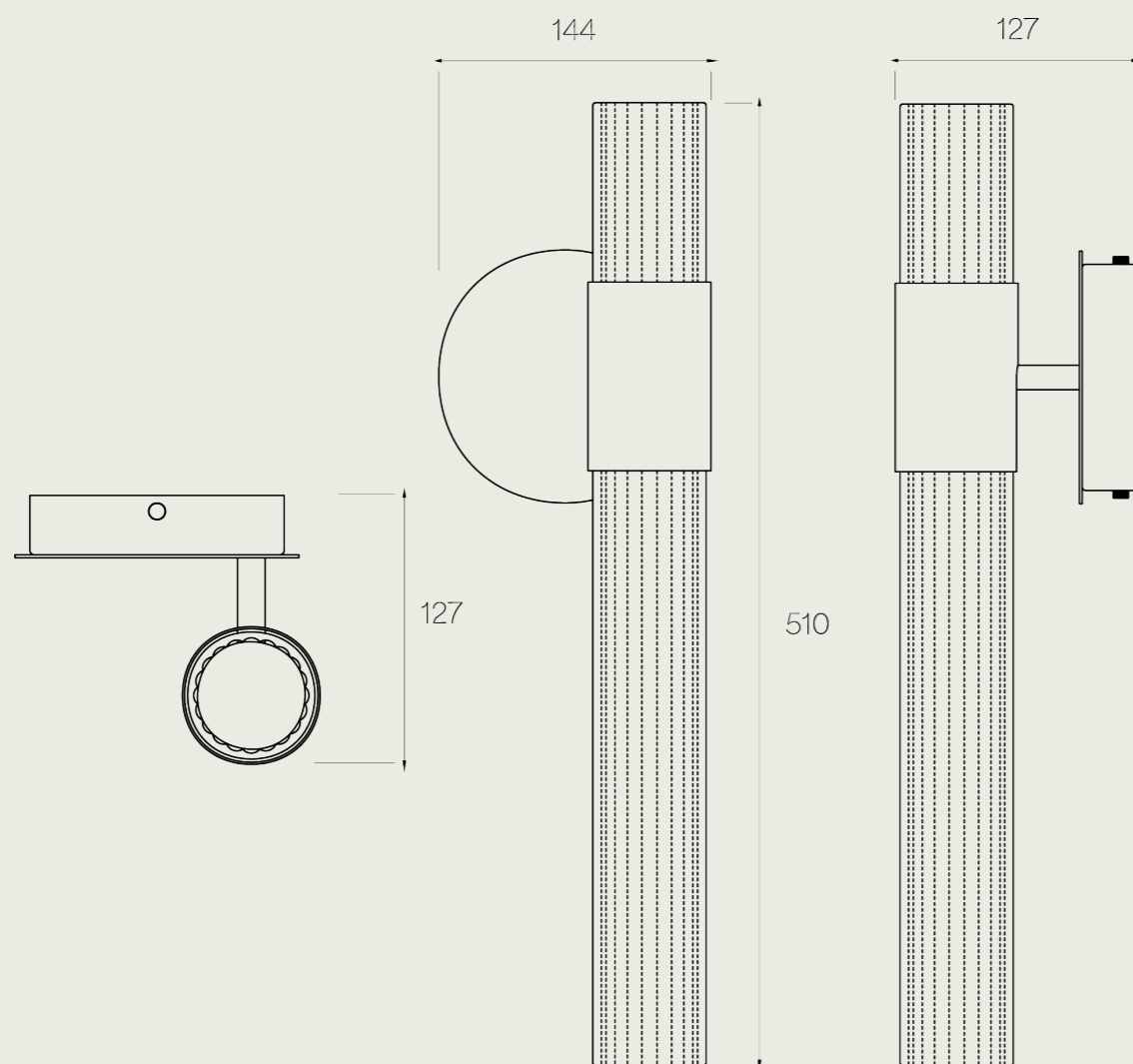

METAL FINISHING/FINITURE



SB.SW02

Type: Wall
 Light Source: Cob LED
 CRI: 90
 Class: IP20
 Colour Temperature: 3000K
 Driver: On/Off - Dimmable on request
 Watt: 16W 100-240V
 Lumens: 1800 Lm

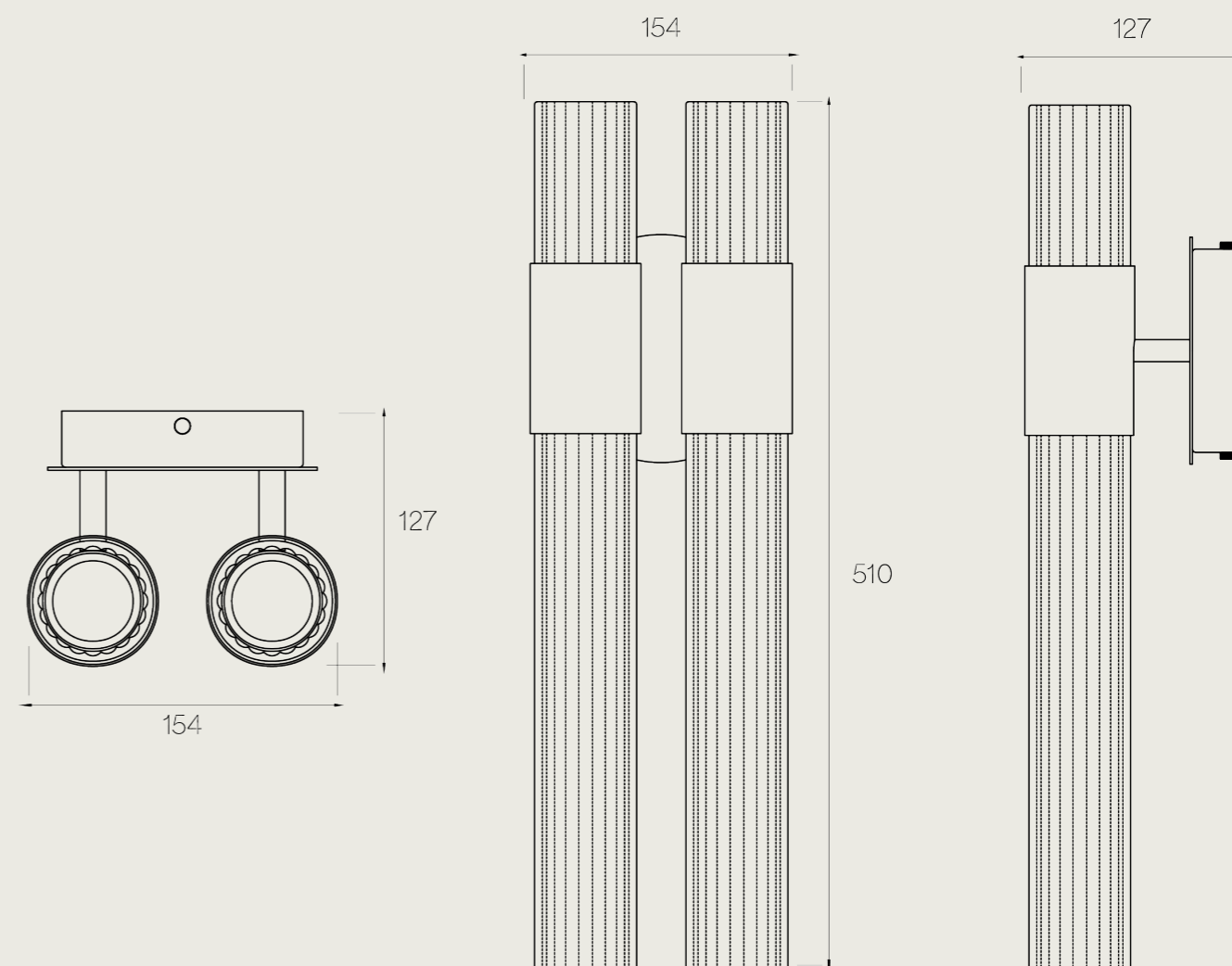

GLASSES/VETRI

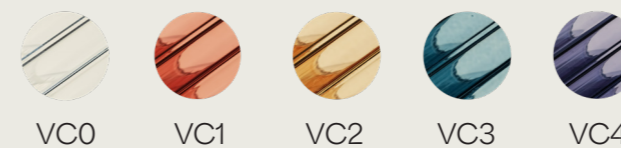

SB.SM01

Type: Wall
 Light Source: Cob LED
 CRI: 90
 Class: IP20
 Colour Temperature: 3000K
 Driver: On/Off - Dimmable on request
 Watt: 8W 100-240V
 Lumens: 900 Lm

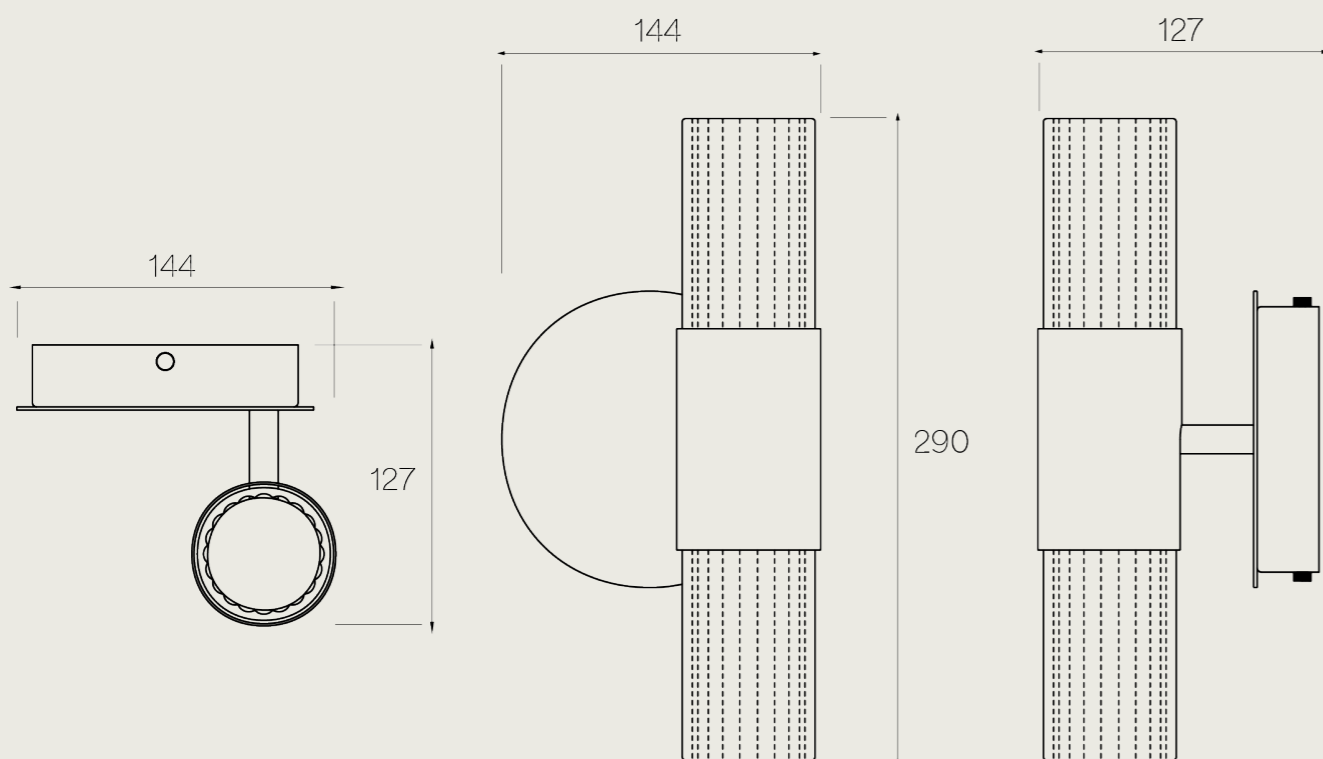

SB.SM02

Type: Wall
 Light Source: Cob LED
 CRI: 90
 Class: IP20
 Colour Temperature: 3000K
 Driver: On/Off - Dimmable on request
 Watt: 16W 100-240V
 Lumens: 1800 Lm

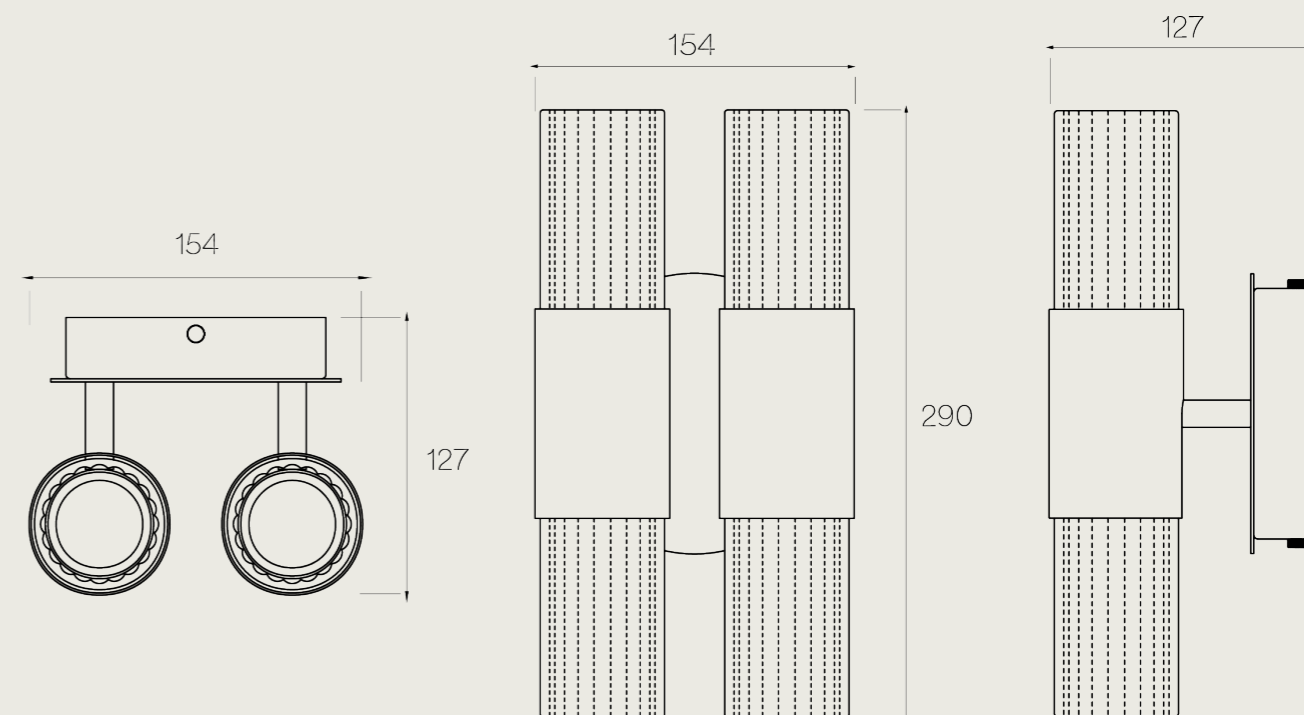

METAL FINISHING/FINITURE



GLASSES/VETRI

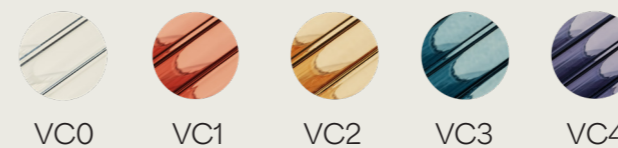

SB.SS02

Type: Ceiling
 Light Source: Cob LED
 CRI: 90
 Class: IP20
 Colour Temperature: 3000K
 Driver: On/Off - Dimmable on request
 Watt: 16W 100-240V
 Lumens: 1800 Lm

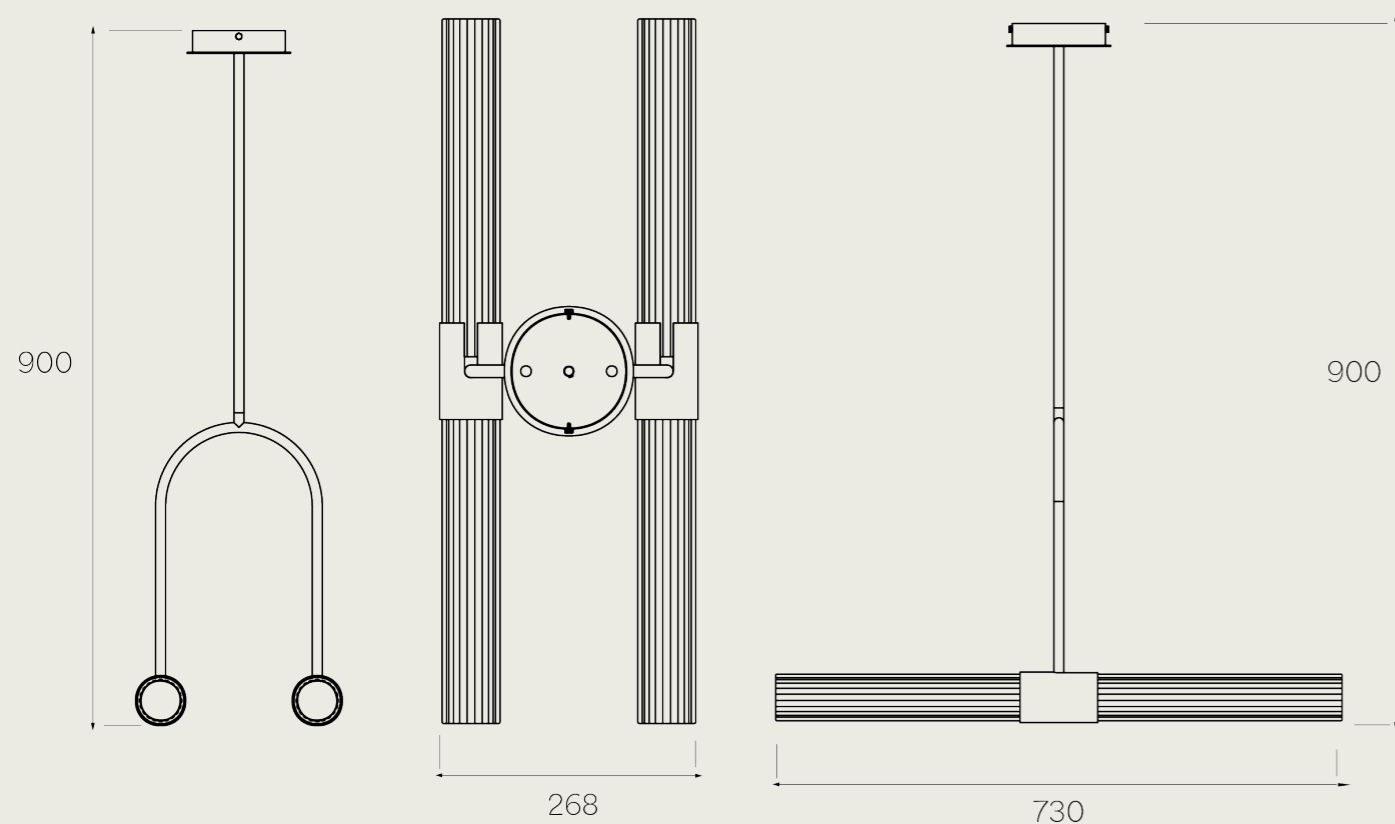

METAL FINISHING/FINITURE



SB.SS02B

Type: Ceiling
 Light Source: Cob LED
 CRI: 90
 Class: IP20
 Colour Temperature: 3000K
 Driver: On/Off - Dimmable on request
 Watt: 16W 100-240V
 Lumens: 1800 Lm

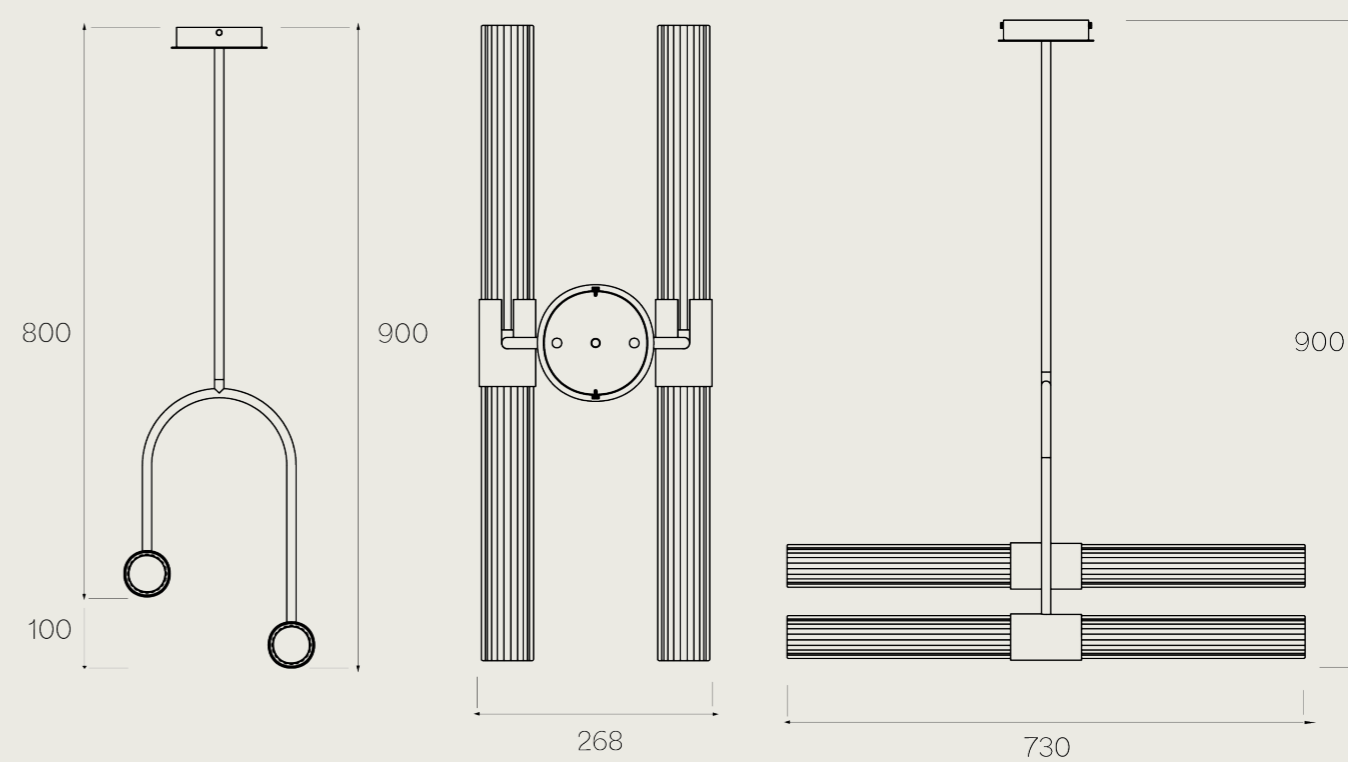

GLASSES/VETRI

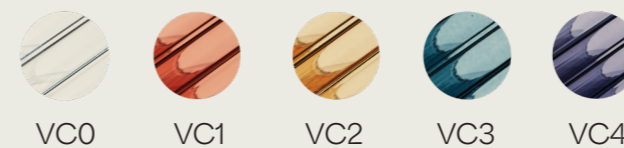

SB.SS03

Type: Ceiling
 Light Source: Cob LED
 CRI: 90
 Class: IP20
 Colour Temperature: 3000K
 Driver: On/Off - Dimmable on request
 Watt: 8W 100-240V
 Lumens: 450 Lm

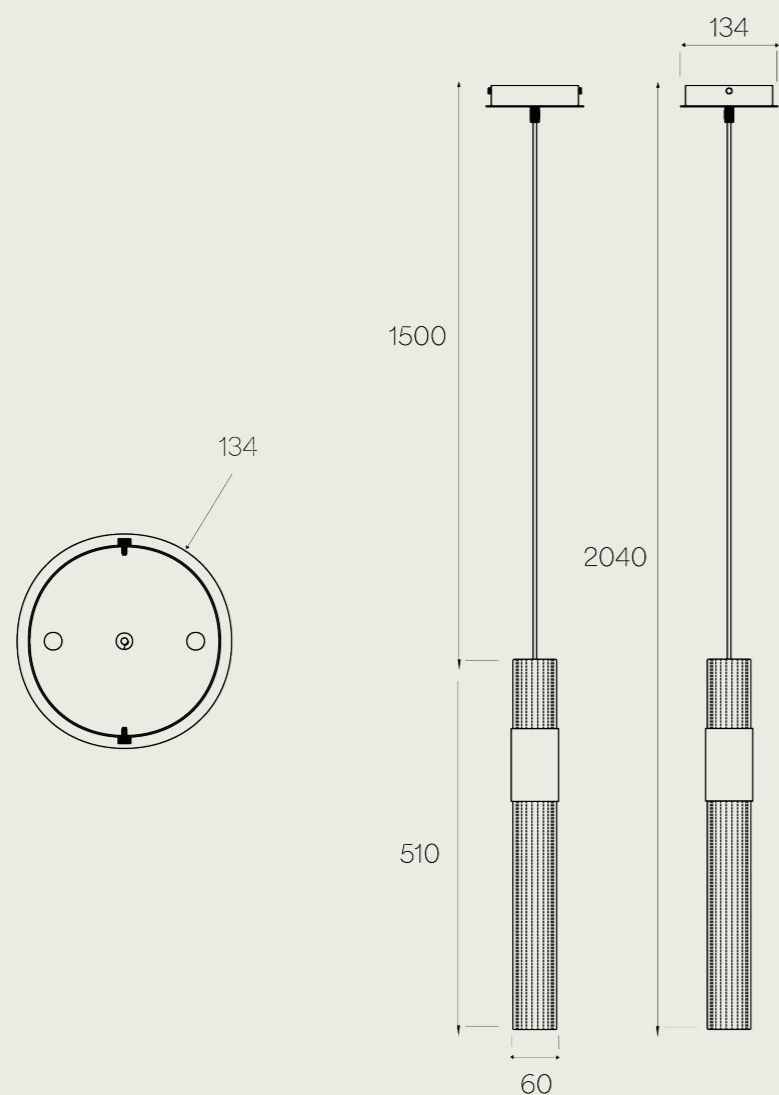

METAL FINISHING/FINITURE



SB.SS04

Type: Ceiling
 Light Source: Cob LED
 CRI: 90
 Class: IP20
 Colour Temperature: 3000K
 Driver: On/Off - Dimmable on request
 Watt: 8W 100-240V
 Lumens: 450 Lm

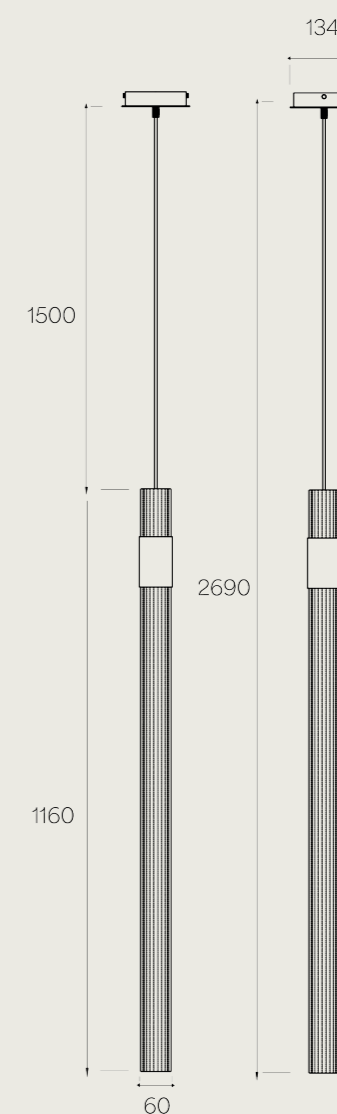

GLASSES/VETRI

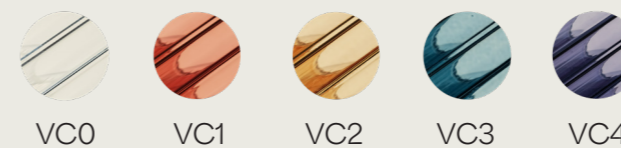

SB.SL01

Type: Wall
Light Source: Cob LED
CRI: 90
Class: IP20
Colour Temperature: 3000K
Driver: On/Off - Dimmable on request
Watt: 8W 100-240V
Lumens: 900 Lm

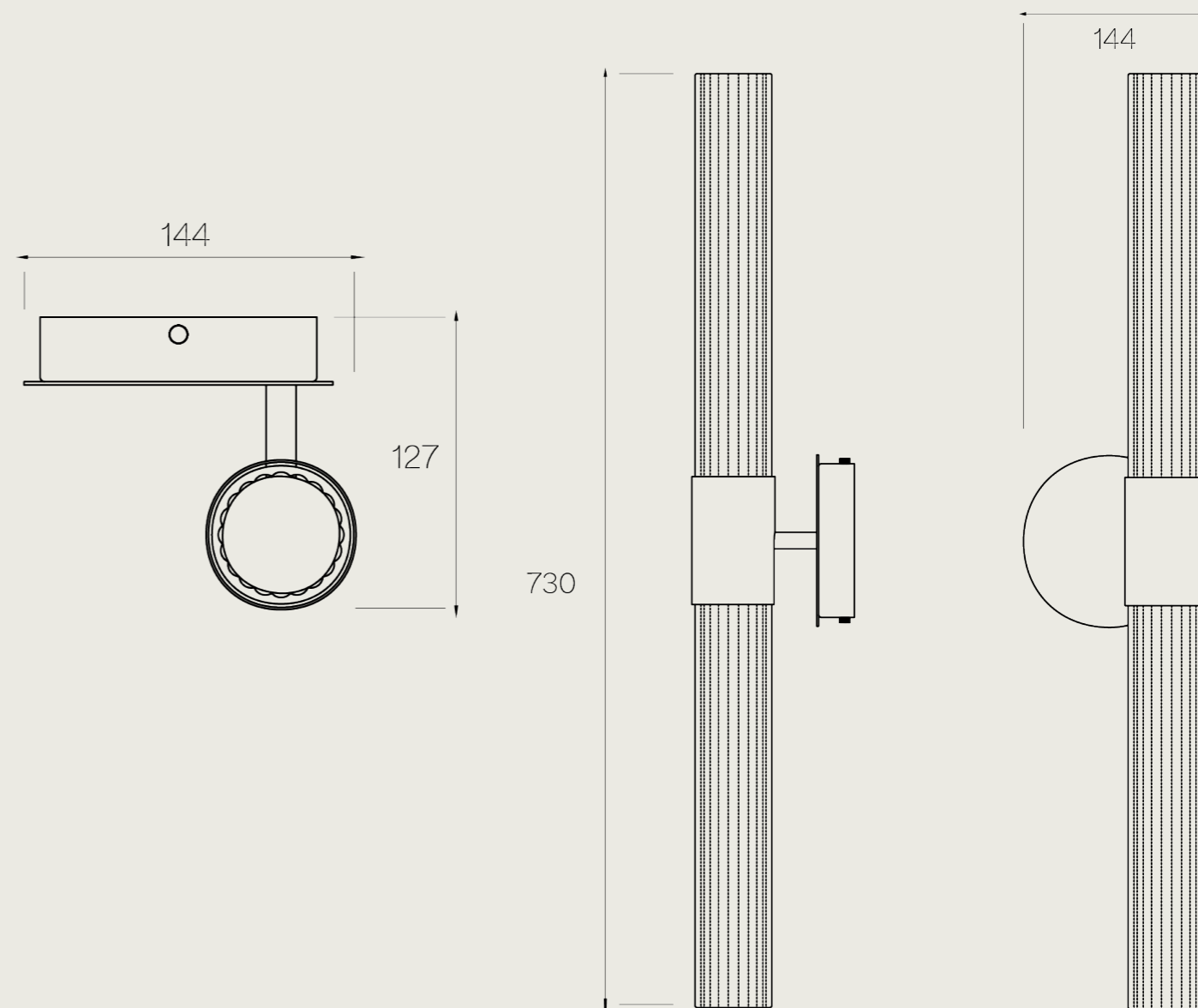

METAL FINISHING/FINITURE



GLASSES/VETRI

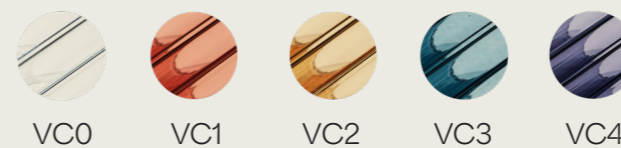

FINITURE/FINISHES

VETRI/GLASSES

STANDARD



VC0

SPECIAL



VC1

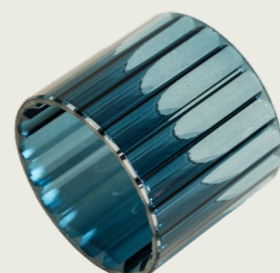

VC3



VC2

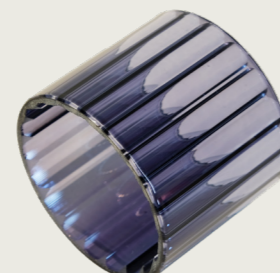

VC4

GALVANICA/GALVANIC

STANDARD

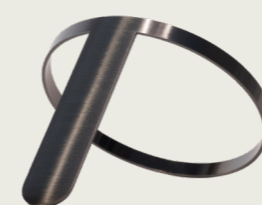

B01
SATIN GUNMETAL



G02
SATIN CHAMPAGNE

SPECIAL



SP3
SATIN BRONZE



SP4
SATIN INOX



SP5
SATIN COPPER



SP6
SHINY GOLD



CRAPA

BALANCE AND HARMONY

Ispirata alla tradizione popolare milanese, Crapa si distingue per forme morbide e perfettamente bilanciate. Le sfere di vetro dialogano con dischi metallici lavorati con precisione artigianale.

Inspired by Milanese popular tradition, Crapa is defined by soft and perfectly balanced shapes. Glass spheres interact with finely crafted metal discs.



CRAPA / SUSPENSION



CRS01-02



CRAPA / WALL



CRW01-02



CRAPA / FLOOR



CRF01



CRAPA / WALL HOTEL



CRH01



CRAPA / TABLE

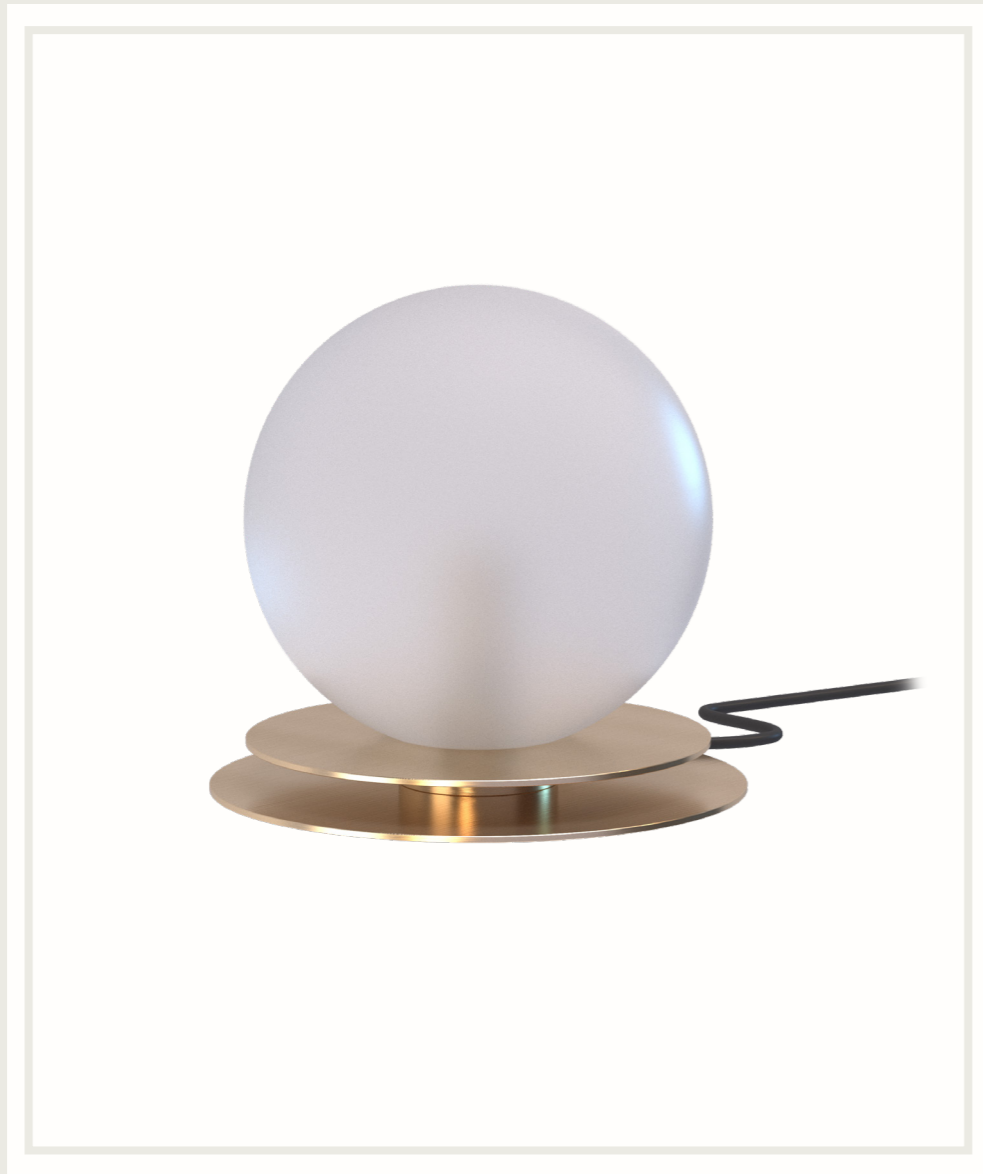

CRT01-02





CRAPA / TECHNICAL DRAWINGS SCHEDE TECNICHE

Tutte le quote e i disegni tecnici riportati nel presente catalogo sono da considerarsi indicativi.
Trattandosi di prodotti artigianali, ogni lampada è realizzata singolarmente e potrebbe presentare
lievi variazioni dimensionali e/o estetiche rispetto a quanto illustrato.

*All dimensions and technical drawings shown in this catalogue are to be considered
indicative. As these are handcrafted products, each lamp is individually made and may
present slight variations in size and/or appearance compared to what is illustrated.*

CRS01

Type: Ceiling
 Light Source: G9 Led Bulb (not included)
 CRI: 90
 Class: IP20
 Colour Temperature: 2700K
 Driver: On/Off - Dimmable on request
 Watt: 8W 100-240V
 Lumens: 800 Lm

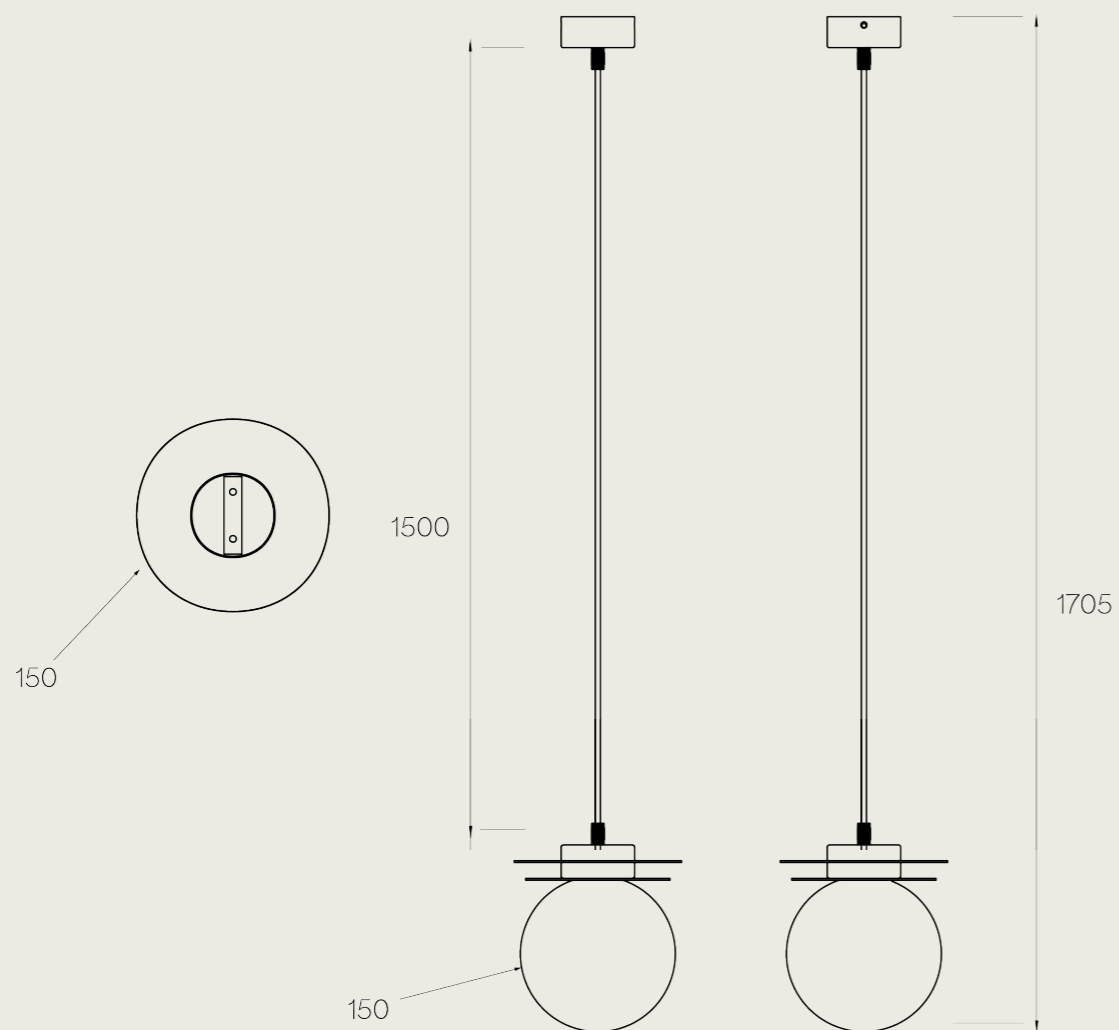

CRS02

Type: Ceiling
 Light Source: G9 Led Bulb (not included)
 CRI: 90
 Class: IP20
 Colour Temperature: 2700K
 Driver: On/Off - Dimmable on request
 Watt: 8W 100-240V
 Lumens: 800 Lm

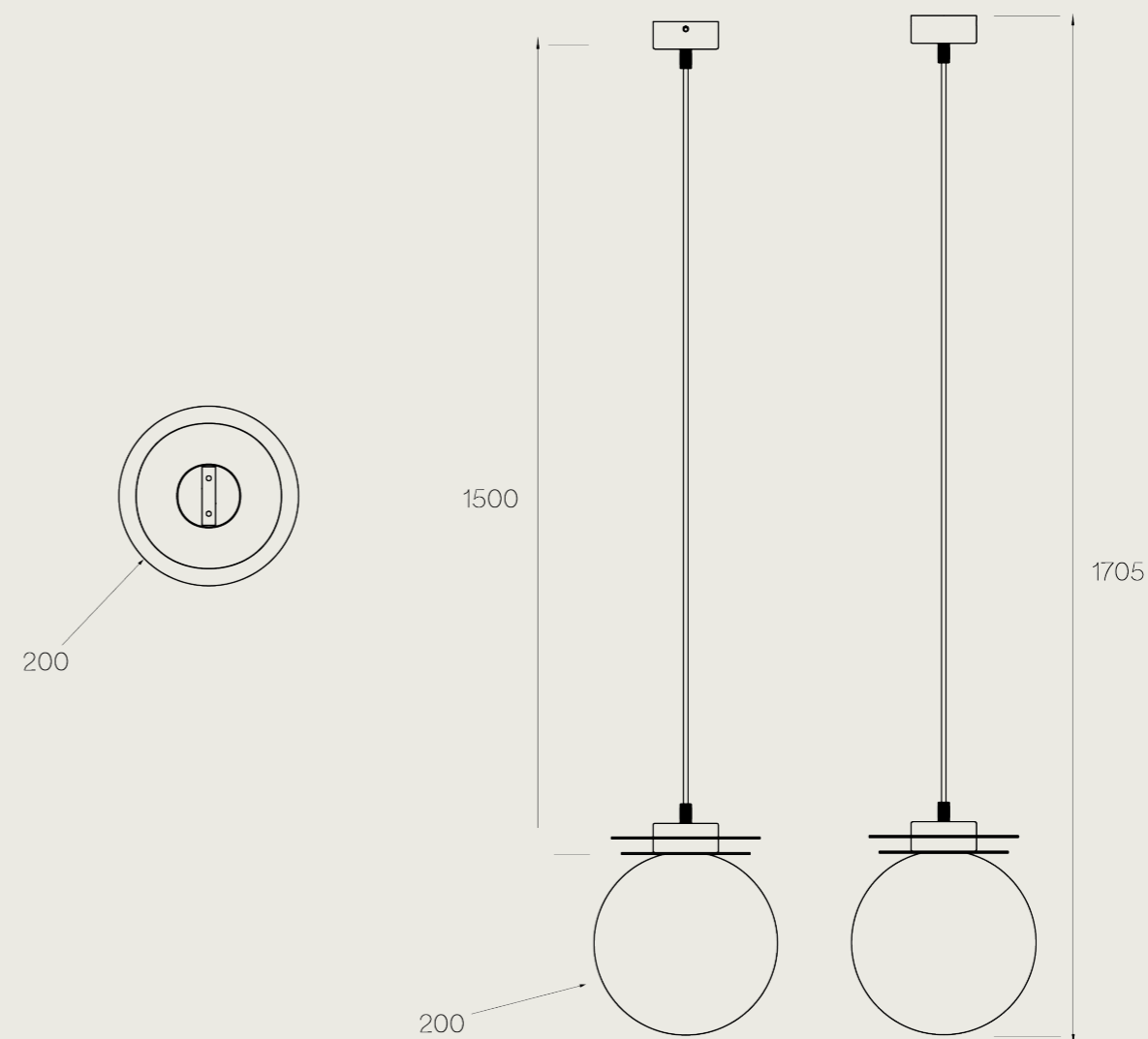

METAL FINISHING/FINITURE



CRW01

Type: Wall
Light Source: G9 Led Bulb (not included)
CRI: 90
Class: IP20
Colour Temperature: 2700K
Driver: On/Off - Dimmable on request
Watt: 8W 100-240V
Lumens: 800 Lm

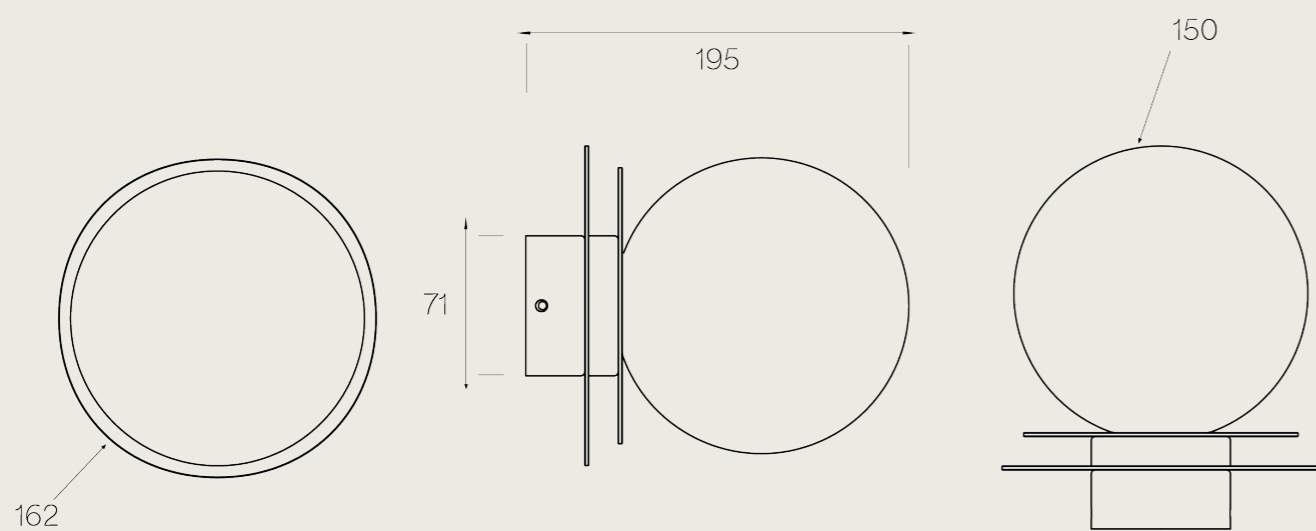

CRW02

Type: Wall
Light Source: G9 Led Bulb (not included)
CRI: 90
Class: IP20
Colour Temperature: 2700K
Driver: On/Off - Dimmable on request
Watt: 8W 100-240V
Lumens: 800 Lm

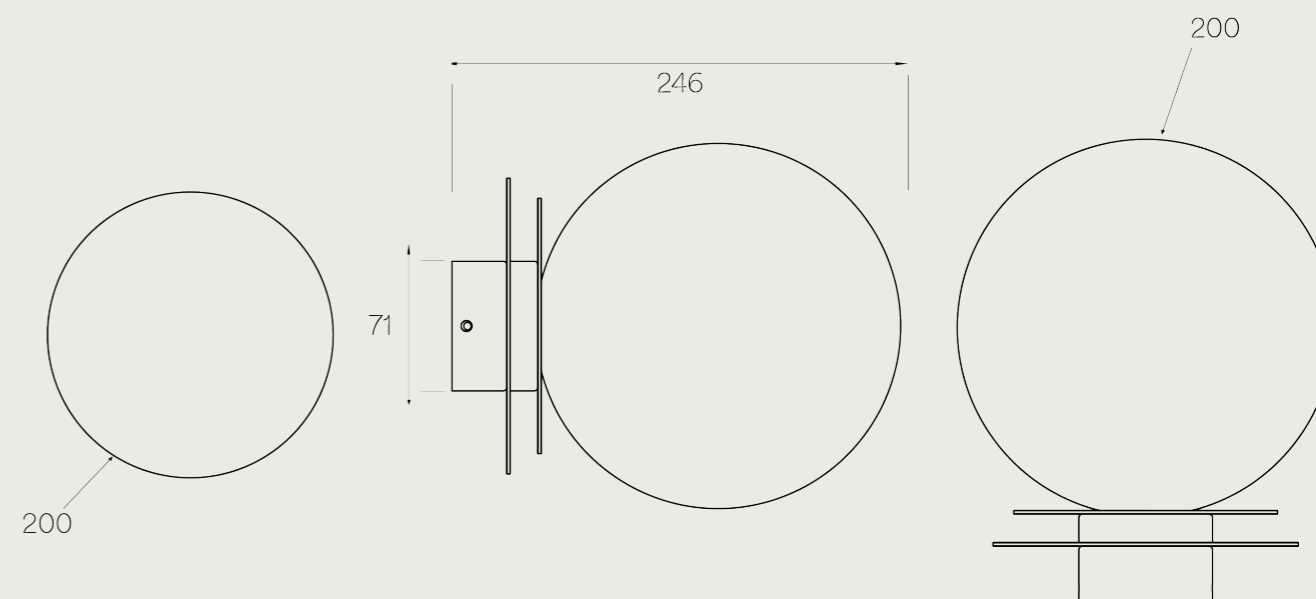

METAL FINISHING/FINITURE



CRF01

Type:	Floor
Light Source:	G9 Led Bulb (not included)
CRI:	90
Class:	IP20
Colour Temperature:	2700K
Driver:	On/Off - Dimmable on request
Watt:	8W 100-240V
Lumens:	800 Lm

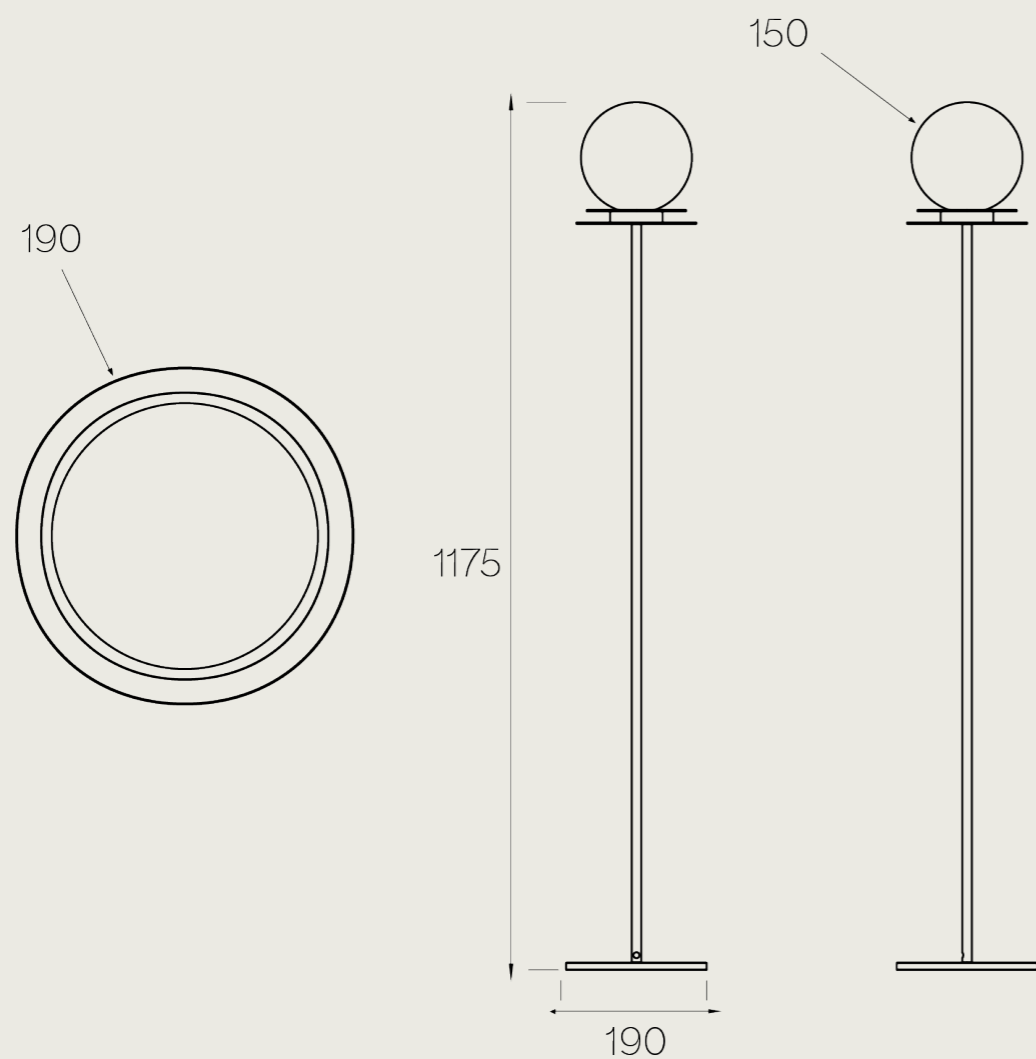

CRH01

Type:	Wall
Light Source:	G9 Led Bulb (not included)
Reading Light:	1/2W Cob Led
CRI:	90
Class:	IP20
Colour Temperature:	2700K
Driver:	On/Off - Dimmable on request
Watt:	8W 100-240V
Lumens:	800 Lm

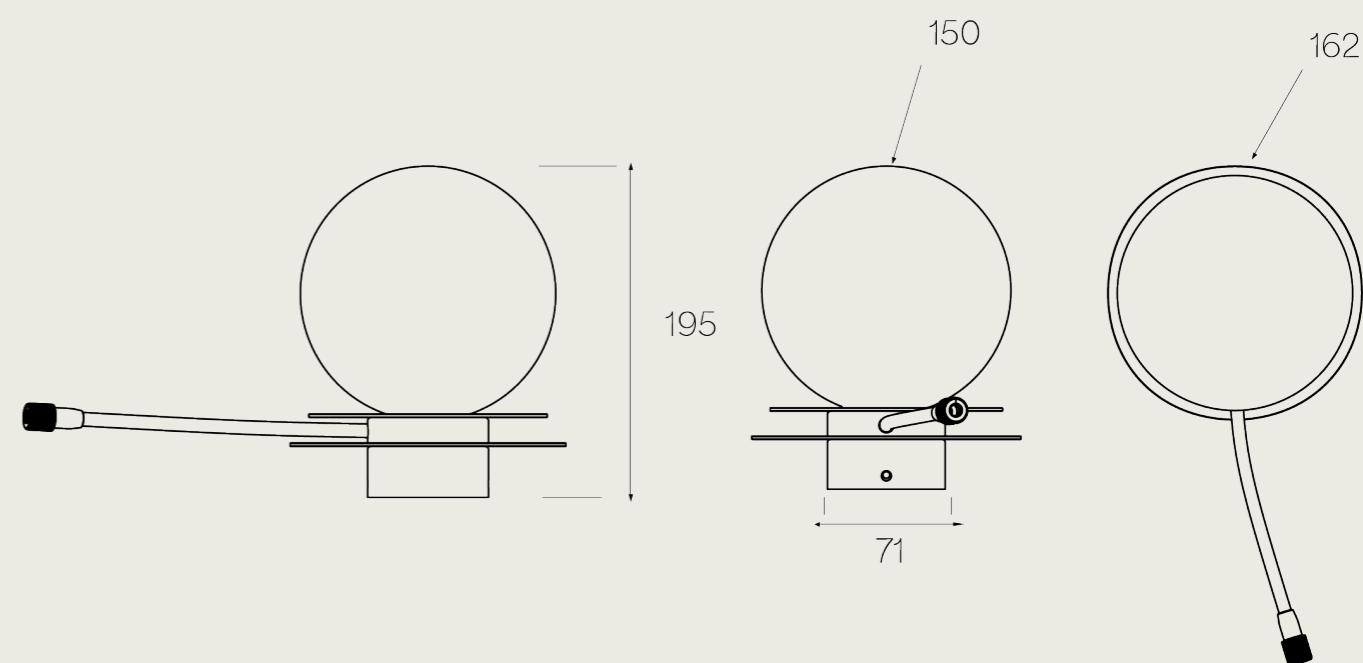

METAL FINISHING/FINITURE



CRT01

Type:	Table
Light Source:	G9 Led Bulb (not included)
CRI:	90
Class:	IP20
Colour Temperature:	2700K
Driver:	On/Off - Dimmable on request
Watt:	8W 100-240V
Lumens:	800 Lm

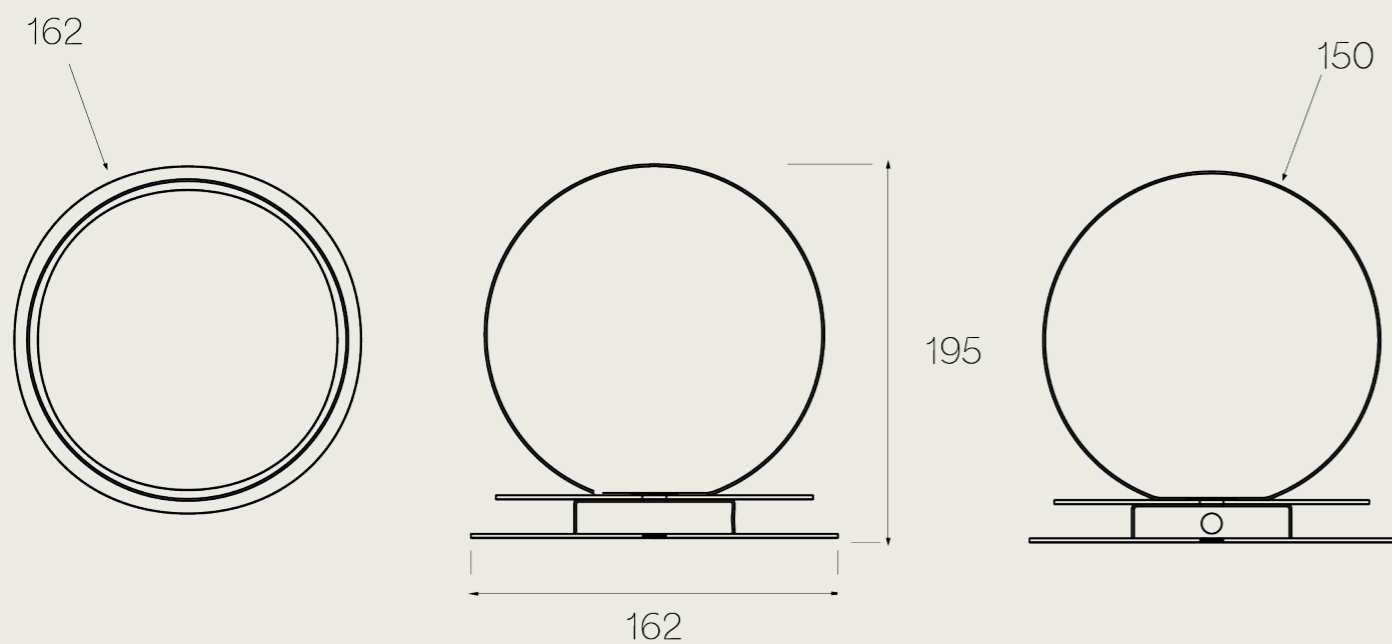

CRT02

Type:	Table
Light Source:	G9 Led Bulb (not included)
CRI:	90
Class:	IP20
Colour Temperature:	2700K
Driver:	On/Off - Dimmable on request
Watt:	8W 100-240V
Lumens:	800 Lm

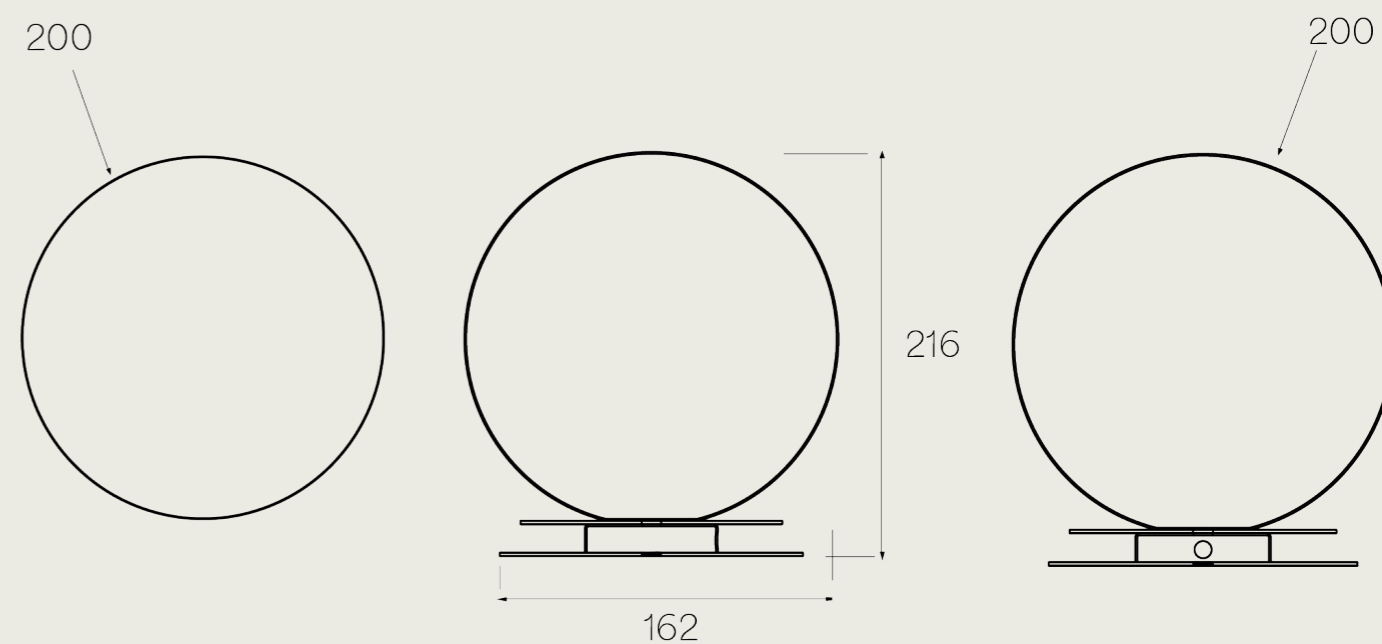

METAL FINISHING/FINITURE



FINITURE/FINISHES

VETRI/GLASSES

STANDARD

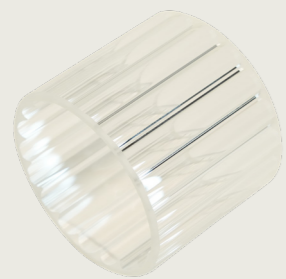

VCO

GALVANICA/GALVANIC

STANDARD



B01
SATIN GUNMETAL



G02
SATIN CHAMPAGNE

SPECIAL



SP3
SATIN BRONZE



SP4
SATIN INOX



SP5
SATIN COPPER



SP6
SHINY GOLD





BALETA

ELEGANCE IN MOTION

La purezza della sfera in vetro incontra il movimento fluido dell'ottone lavorato, generando una lampada contemporanea e raffinata.

The purity of the glass sphere meets the fluid movement of crafted brass, creating a refined contemporary lamp.



BALETA / SUSPENSION



BLS01-02



BALETA / TABLE



BLT01-02



BALETA / WALL



BLW01





BALETA / TECHNICAL DRAWINGS

SCHEDE TECNICHE

Tutte le quote e i disegni tecnici riportati nel presente catalogo sono da considerarsi indicativi. Trattandosi di prodotti artigianali, ogni lampada è realizzata singolarmente e potrebbe presentare lievi variazioni dimensionali e/o estetiche rispetto a quanto illustrato.

All dimensions and technical drawings shown in this catalogue are to be considered indicative. As these are handcrafted products, each lamp is individually made and may present slight variations in size and/or appearance compared to what is illustrated.

BLS01

Type: Suspension
Light Source: G9 Led Bulb (not included)
CRI: 90
Class: IP20
Colour Temperature: 2700K
Driver: On/Off - Dimmable on request
Watt: 8W 100-240V
Lumens: 800 Lm

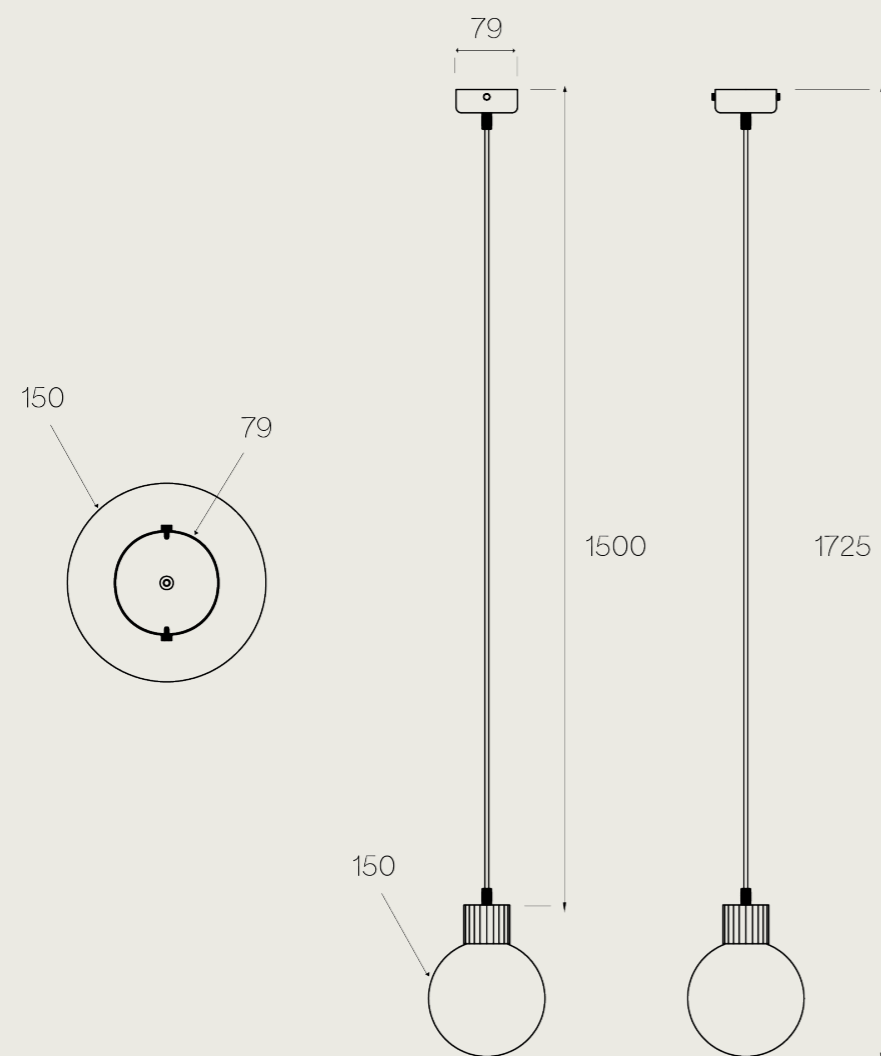

BLS02

Type: Suspension
Light Source: G9 Led Bulb (not included)
CRI: 90
Class: IP20
Colour Temperature: 2700K
Driver: On/Off - Dimmable on request
Watt: 8W 100-240V
Lumens: 800 Lm

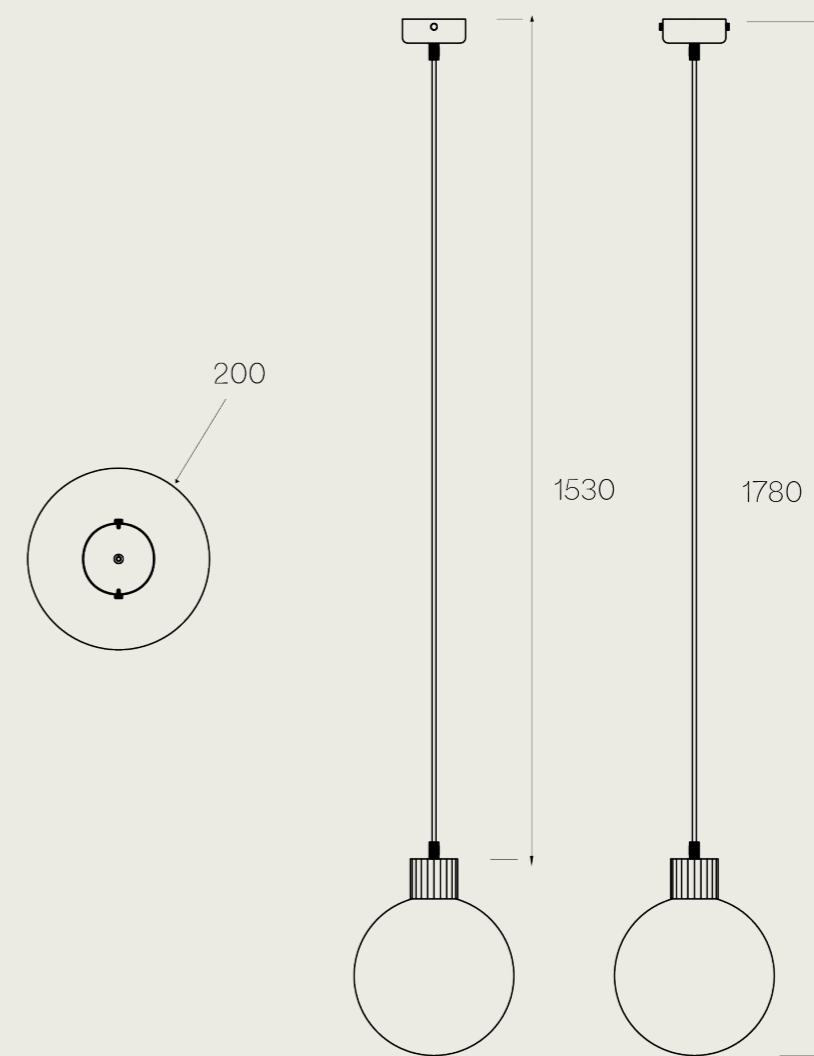

METAL FINISHING/FINITURE



BLT01

Type:	Table
Light Source:	G9 Led Bulb (not included)
CRI:	90
Class:	IP20
Colour Temperature:	2700K
Driver:	On/Off - Dimmable on request
Watt:	8W 100-240V
Lumens:	800 Lm

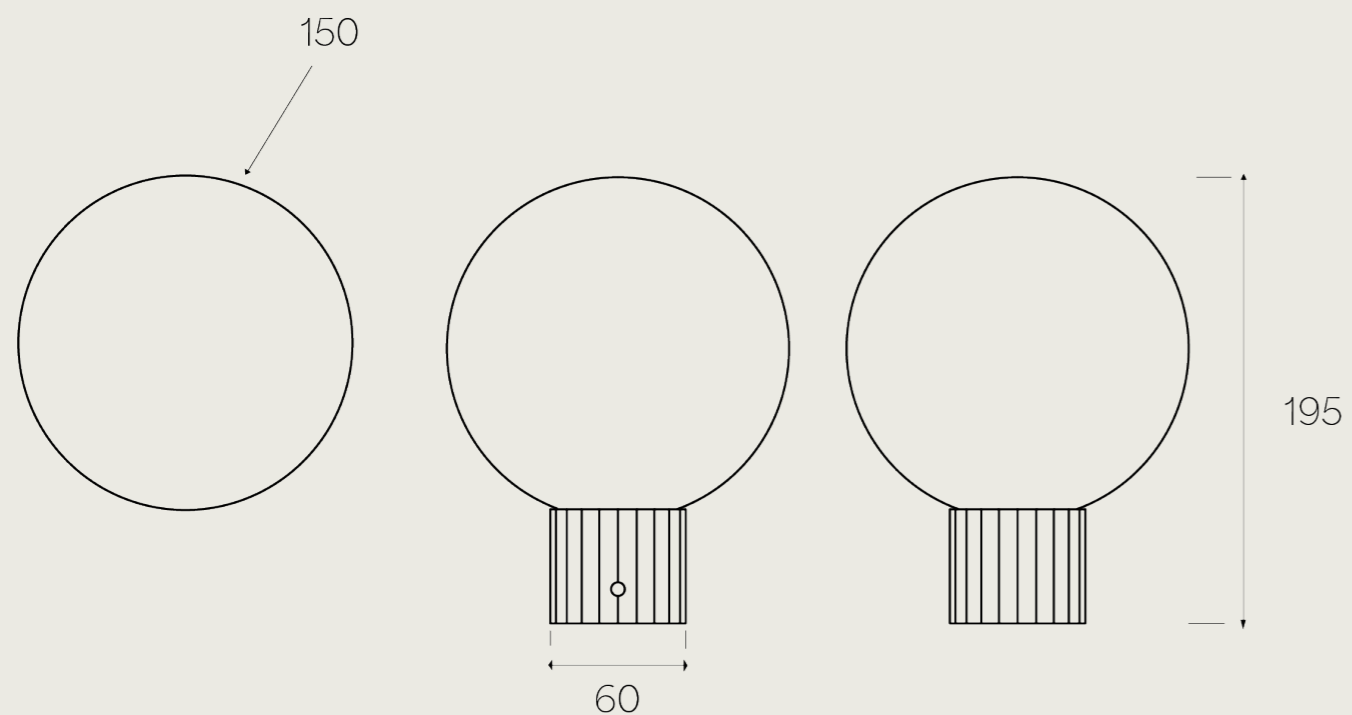

BLT02

Type:	Table
Light Source:	G9 Led Bulb (not included)
CRI:	90
Class:	IP20
Colour Temperature:	2700K
Driver:	On/Off - Dimmable on request
Watt:	8W 100-240V
Lumens:	800 Lm

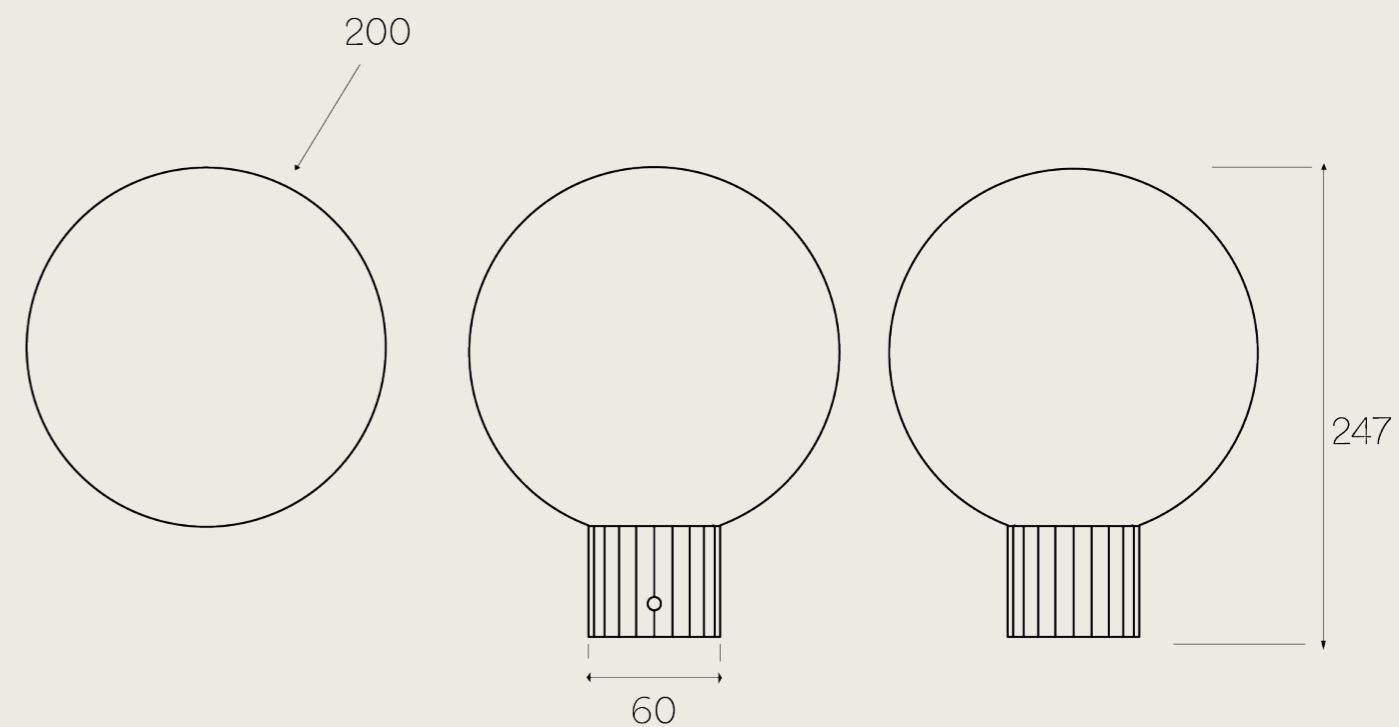

METAL FINISHING/FINITURE



BLW01

Type:	Wall
Light Source:	G9 Led Bulb (not included)
CRI:	90
Class:	IP20
Colour Temperature:	2700K
Driver:	On/Off - Dimmable on request
Watt:	8W 100-240V
Lumens:	800 Lm

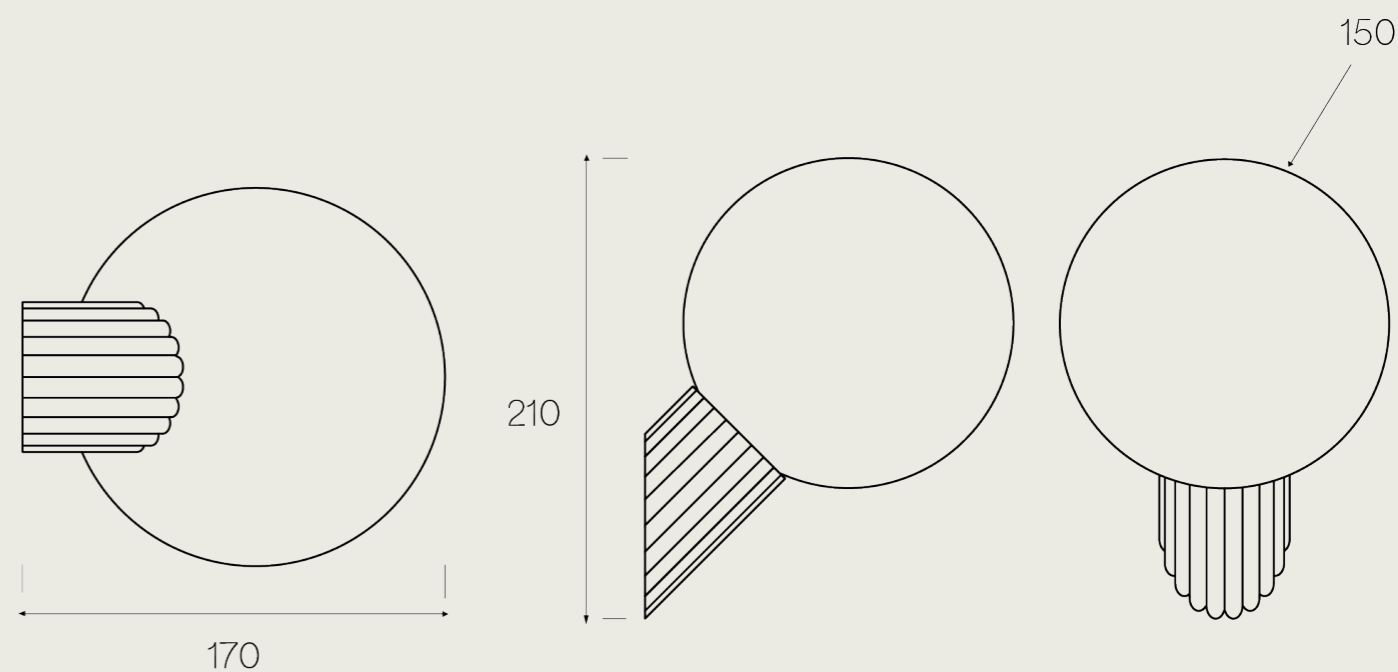

METAL FINISHING/FINITURE



FINITURE/FINISHES

VETRI/GLASSES

STANDARD



VCO

GALVANICA/GALVANIC

STANDARD



B01
SATIN GUNMETAL



G02
SATIN CHAMPAGNE

SPECIAL



SP3
SATIN BRONZE



SP4
SATIN INOX



SP5
SATIN COPPER



SP6
SHINY GOLD





LUSTRIN

A JEWEL OF LIGHT

Ispirata alle decorazioni luminose dell'alta sartoria storica, Lustrin si distingue per le scanalature della superficie che trasformano la lampada in un oggetto prezioso.

Inspired by the luminous embellishments of historic haute couture, Lustrin stands out for its grooved surface, transforming the lamp into a precious luminous object.

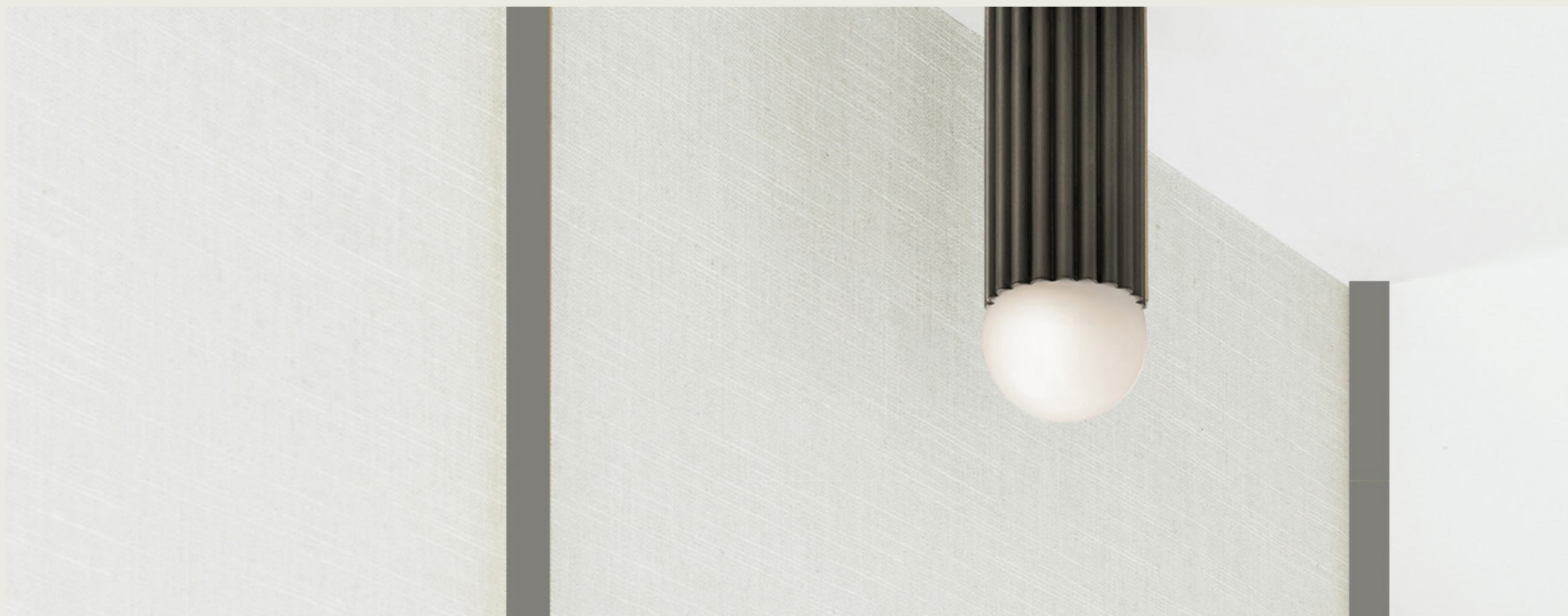

LUSTRIN / SUSPENSION



LU.LS01



LUSTRIN / TRIPLE SUSPENSION



LU.LS02



LUSTRIN / WALL



LU.LW01



LUSTRIN / WALL DOUBLE



LU.LW02



LUSTRIN / CEILING



LU.LC01



LUSTRIN / SPOTLIGHT



LU.LC02

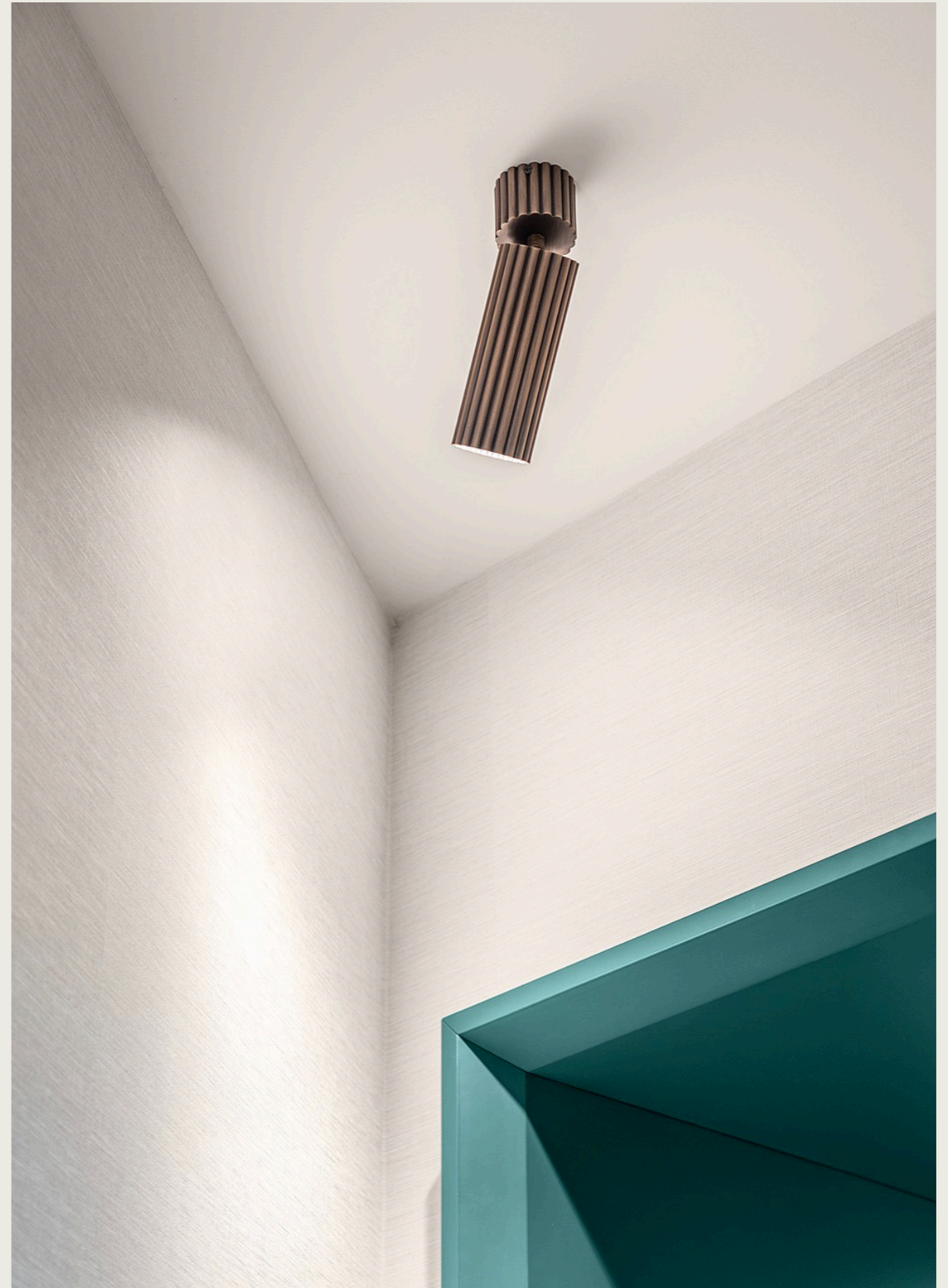

LUSTRIN / RAIL



LU.LB01





LUSTRIN / TECHNICAL DRAWINGS

SCHEDE TECNICHE

Tutte le quote e i disegni tecnici riportati nel presente catalogo sono da considerarsi indicativi. Trattandosi di prodotti artigianali, ogni lampada è realizzata singolarmente e potrebbe presentare lievi variazioni dimensionali e/o estetiche rispetto a quanto illustrato.

All dimensions and technical drawings shown in this catalogue are to be considered indicative. As these are handcrafted products, each lamp is individually made and may present slight variations in size and/or appearance compared to what is illustrated.

LU.LS01

Type: Suspension
 Light Source: G10 LED Bulb (not included)
 CRI: 90
 Class: IP20
 Colour Temperature: 3000K
 Driver: On/Off - Dimmable on request
 Watt: 6W 110-240V
 Lumens: 450 Lm

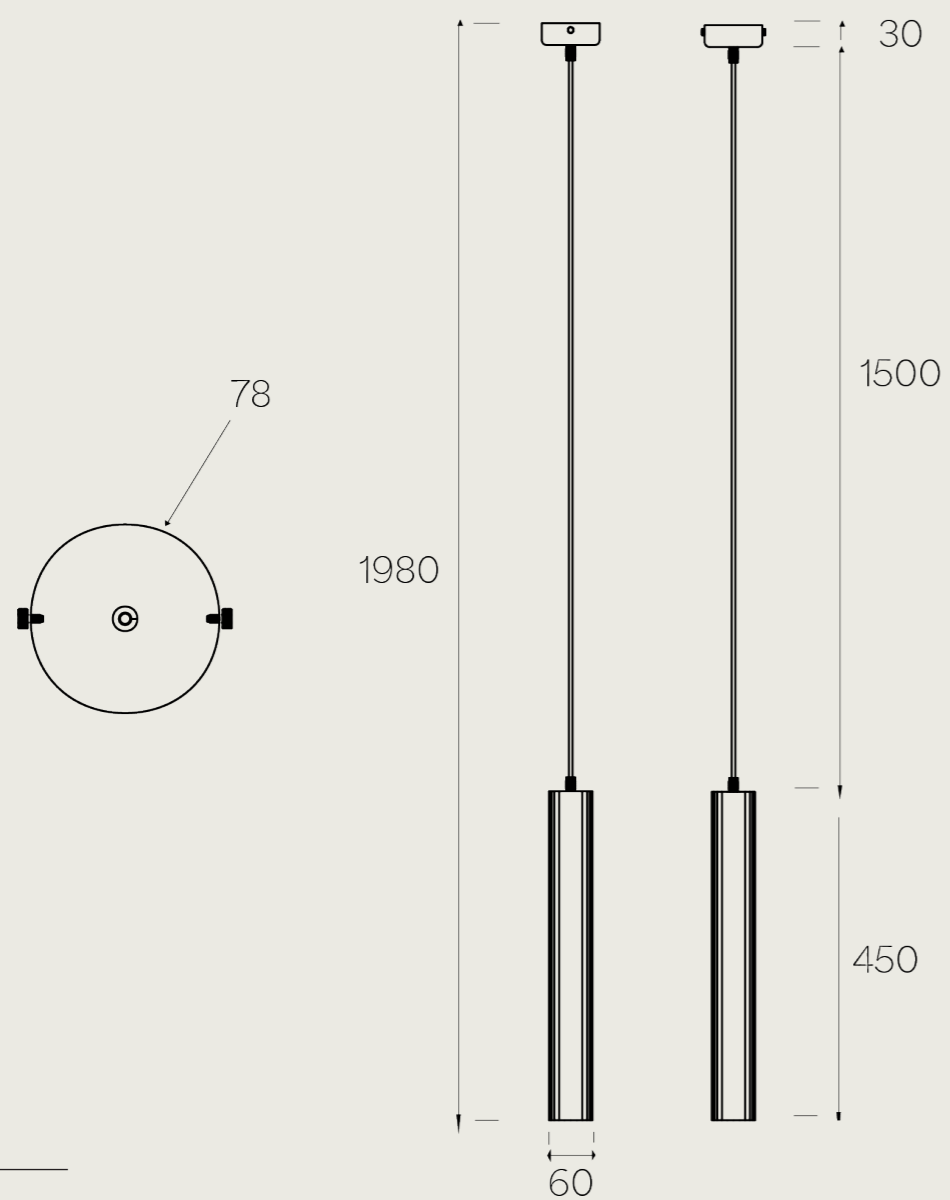

LU.LS02

Type: Suspension
 Light Source: G10 LED Bulb (not included)
 CRI: 90
 Class: IP20
 Colour Temperature: 3000K
 Driver: On/Off - Dimmable on request
 Watt: 6W*3 110-240V
 Lumens: 1350 Lm

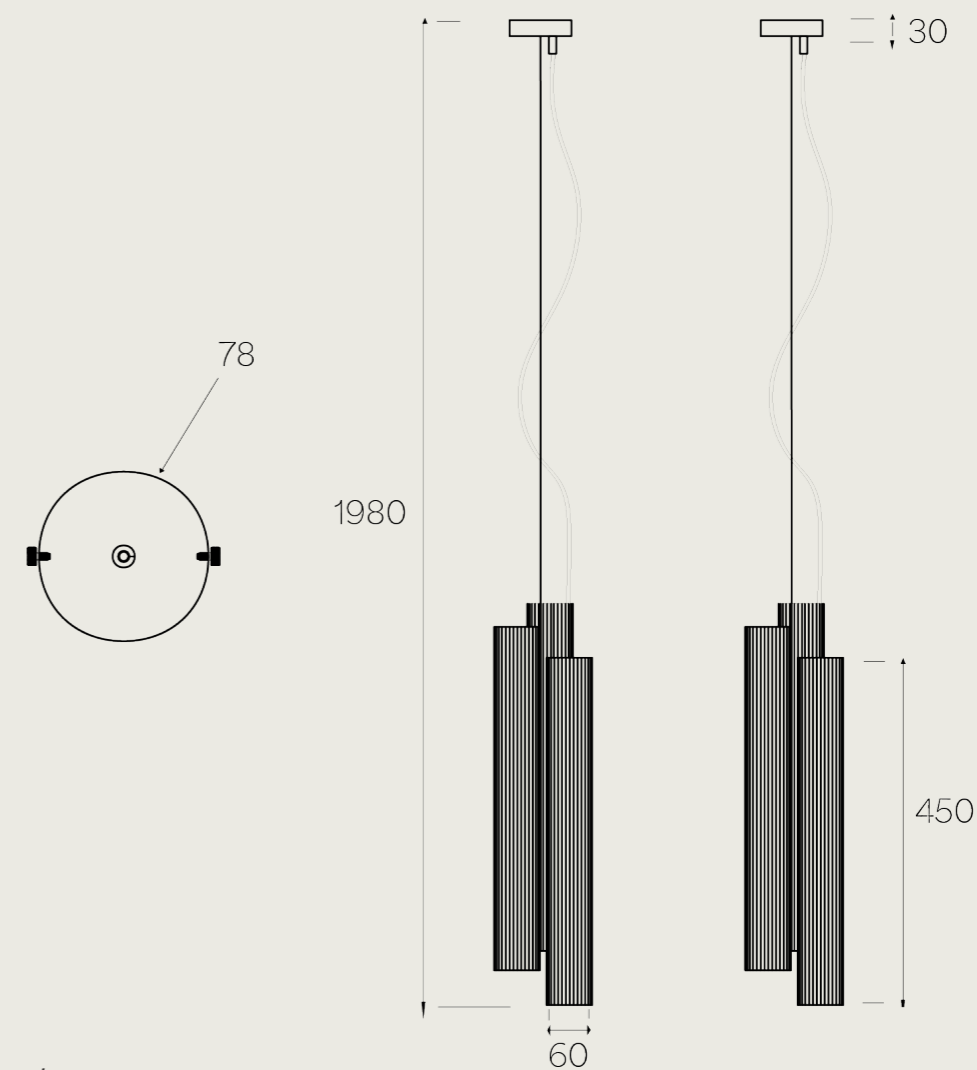

METAL FINISHING/FINITURE



LU.LW01

Type: Wall
 Light Source: G10 LED Bulb (not included)
 CRI: 90
 Class: IP20
 Colour Temperature: 3000K
 Driver: On/Off - Dimmable on request
 Watt: 6W*2 110-240V
 Lumens: 900 Lm

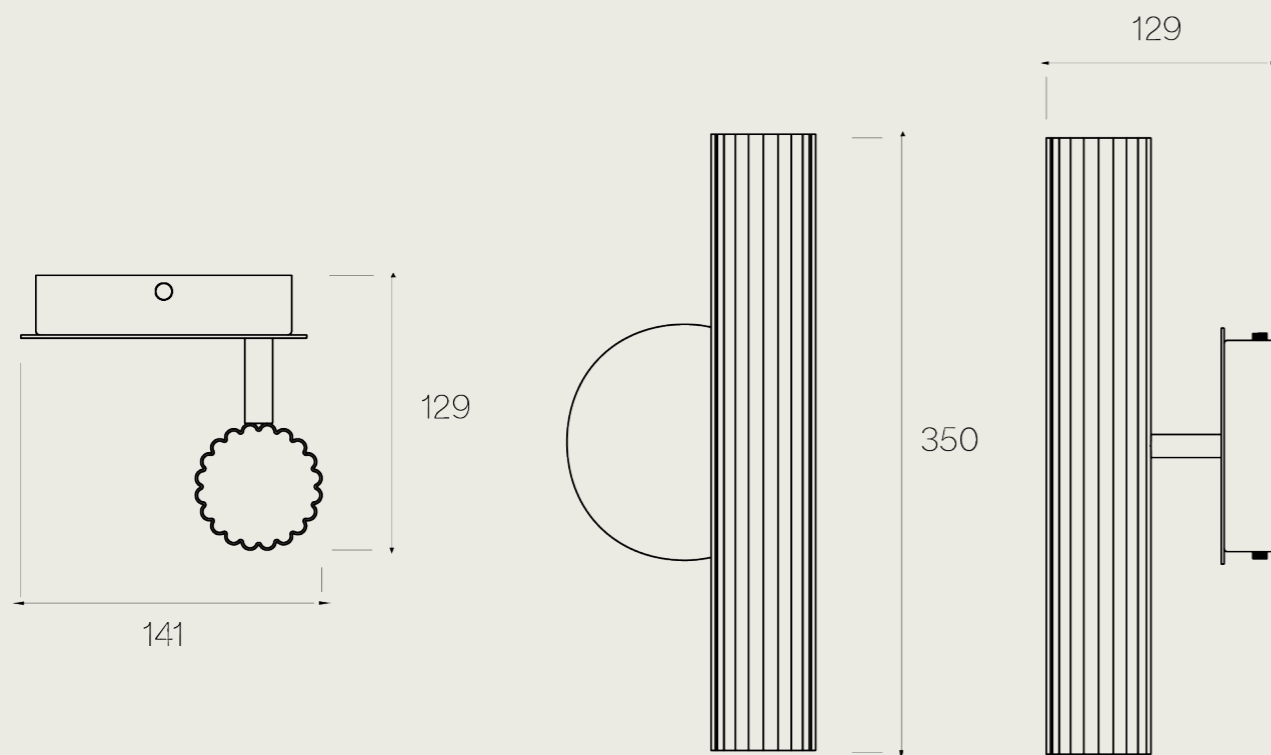

LU.LW02

Type: Wall
 Light Source: G10 LED Bulb (not included)
 CRI: 90
 Class: IP20
 Colour Temperature: 3000K
 Driver: On/Off - Dimmable on request
 Watt: 6W*2 110-240V
 Lumens: 900 Lm

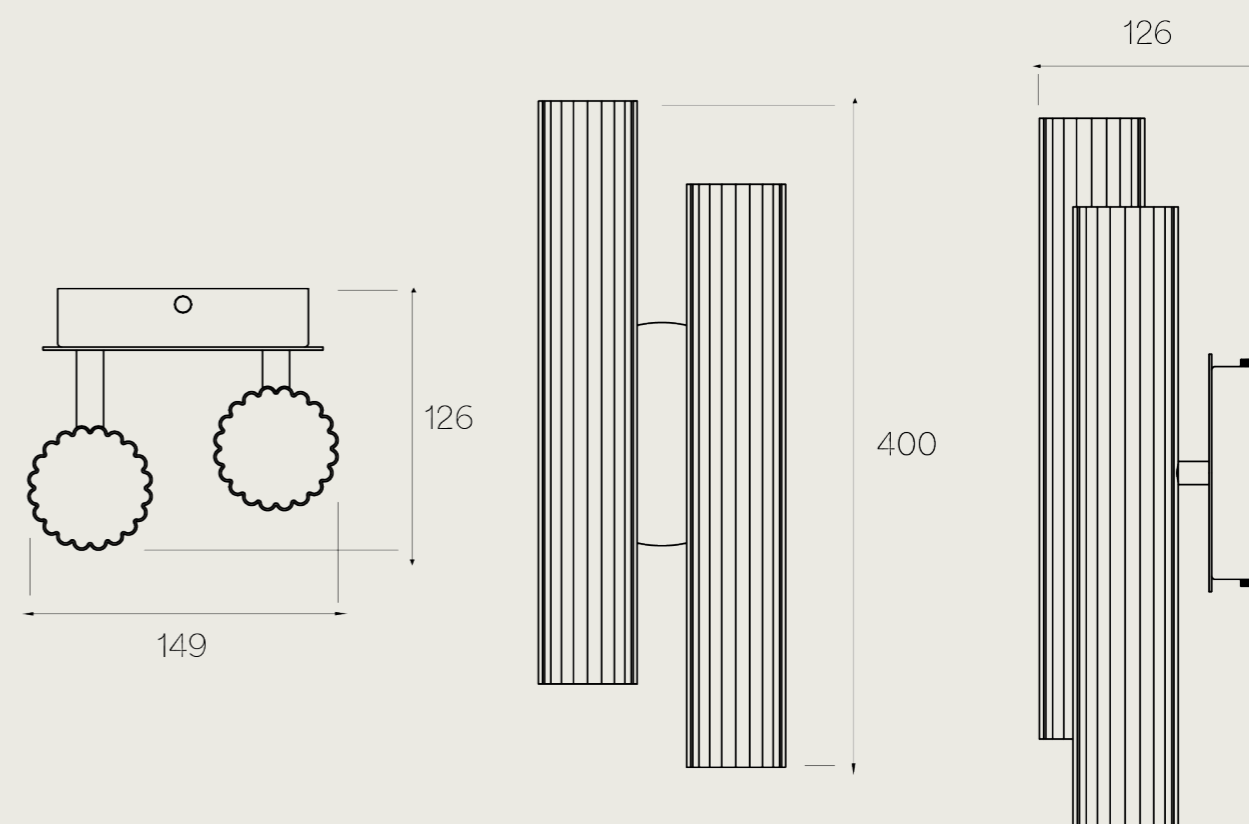

METAL FINISHING/FINITURE



LU.LC01

Type:	Ceiling
Light Source:	E27 LED Bulb (not included)
CRI:	90
Class:	IP20
Colour Temperature:	3000K
Driver:	On/Off
Watt:	9W 110-240V
Lumens:	900 Lm

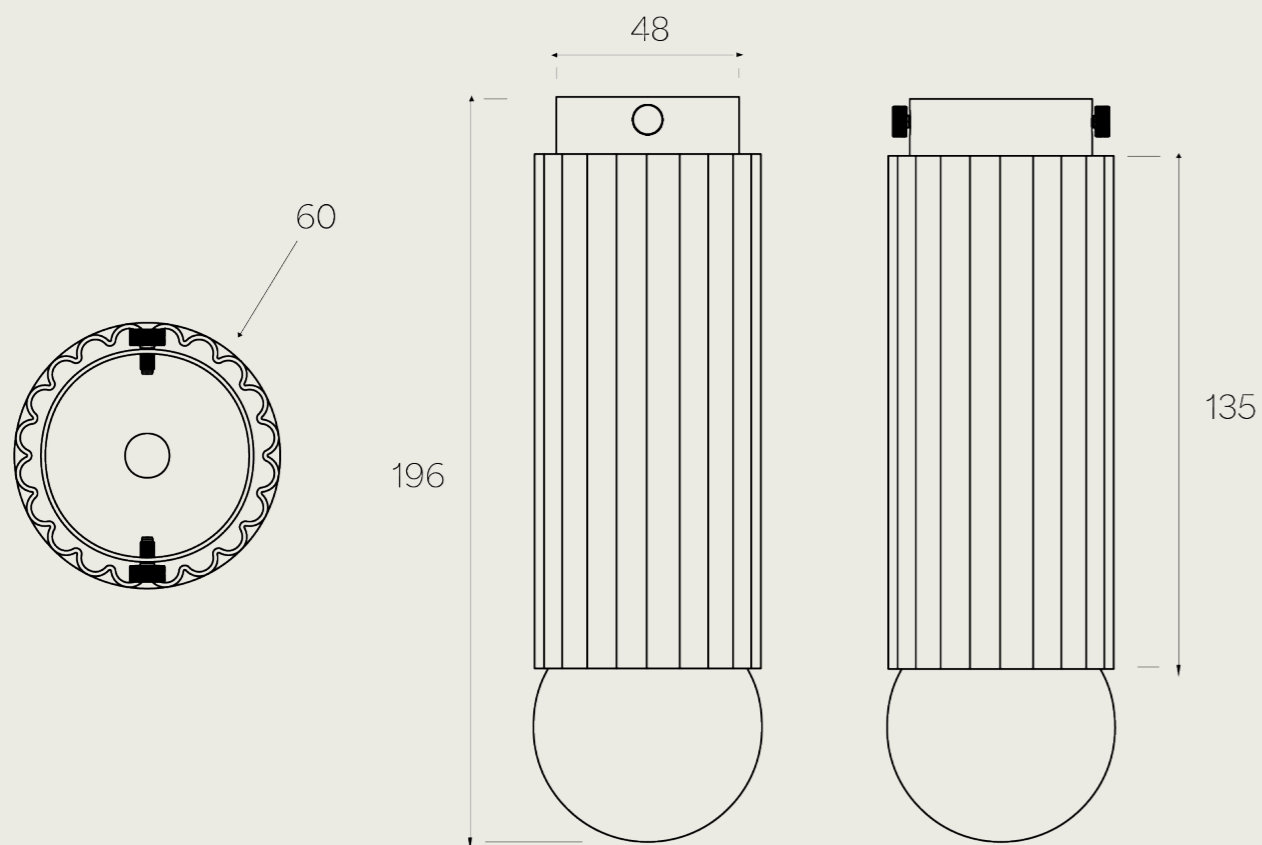

LU.LC02

Type:	Ceiling
Light Source:	Gu10 LED Bulb (not included)
CRI:	90
Class:	IP20
Colour Temperature:	3000K
Driver:	On/Off
Watt:	6W 110-240V
Lumens:	450 Lm

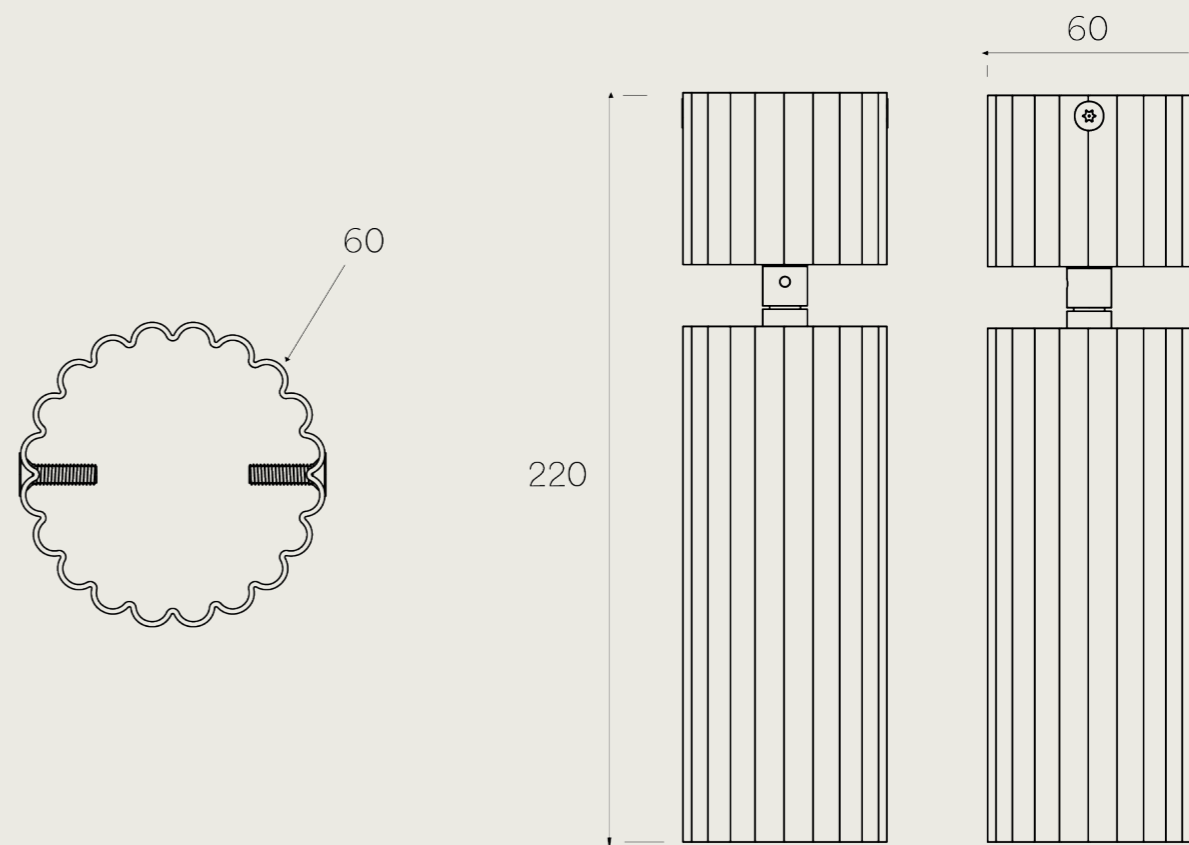

METAL FINISHING/FINITURE



LU.LB01

Type:	Ceiling
Light Source:	Gu10 LED Bulb (not included)
CRI:	90
Class:	IP20
Colour Temperature:	3000K
Driver:	On/Off
Watt:	6W 110-240V
Lumens:	450 Lm

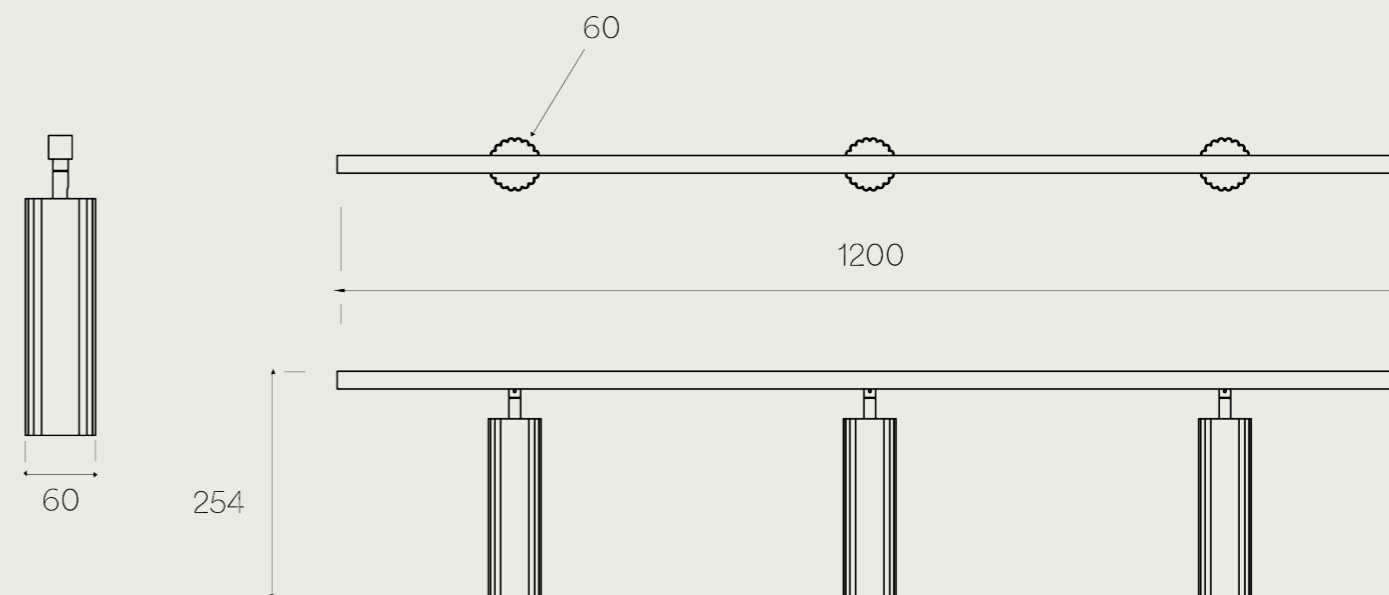

METAL FINISHING/FINITURE



FINITURE/FINISHES

GALVANICA/GALVANIC

STANDARD



B01
SATIN GUNMETAL



G02
SATIN CHAMPAGNE

SPECIAL



SP3
SATIN BRONZE



SP4
SATIN INOX



SP5
SATIN COPPER



SP6
SHINY GOLD

LUCE ◦ TU

SHOWROOM
VIA LAMBRATE 3 - MILANO

DESIGN LAB
PIAZZA BERTARELLI 4 - MILANO

INFO@LUCETU.COM | WWW.LUCETU.COM